



CORNER OF 4TH AVENUE AND UNIVERSITY BOULEVARD IN FOREGROUND

INFILL INCENTIVE DISTRICT
DESIGN PACKAGE FOR

THE
TRINITY

400 E UNIVERSITY BOULEVARD, TUCSON, AZ

R + R Develop www.rplusrdevelop.com
Bourn Companies www.bourncompanies.com
Rob Paulus Architects www.robpaulus.com

30 MAY 2017

TABLE OF CONTENTS

APPLICATION	3
PROJECT STATEMENT	4
PROJECT SITE AERIAL	5-6
EXISTING SITE PHOTOS	7
PRECEDENT IMAGES	8-13
SITE PLAN	14-16
FLOOR PLANS	17
ELEVATIONS	18-21
DESIGN STANDARDS	22-24

APPLICATION

Zoning Administration



APPLICATION

Case Number _____

Date Accepted: _____

PROPERTY LOCATION INFORMATION

Property Development (Project) Name (IF APPLICABLE): The Trinity

Property Address: 400 E. University Blvd. 85705

Applicable Area/Neighborhood/Overlay: West University

Zoning: PAD(H) - 31

Legal Description: TUCSON LOTS 2 3 6 7 & W115' LOTS 10 & 11 EXC RD BLK 42

Pima County Tax Parcel Number/s: 117-03-321F, 117-03-3270, 117-03-321B, 117-03-3260
117-03-3280, 117-03-321D, 117-03-3190

Site and Building Area (sq ft): 2.79 acres

APPLICANT INFORMATION (The person processing the application and designated to receive notices):

APPLICANT NAME: R+R Develop, Randi Dorman

ADDRESS: 990 E. 17th St., Suite 100 85719

PHONE: (520) 624-9805 / (520) 904-4242 FAX: () _____

EMAIL: randidorman1@gmail.com, rob@robpaulus.com

PROPERTY OWNER NAME (If ownership in escrow, please note): Trinity Presbyterian Church

PHONE: (520) 623-2579 FAX: () _____

PROJECT TYPE (check all that apply):
() New building on vacant land
() New addition to existing building
() Change of use to existing building
(X) New building on developed land
() Other

Related Permitted Activity Number(s): HPZ-17-40

DESCRIPTION OF USE: Mixed Use - Residential, Retail, Office

I hereby certify that all information contained in this application is complete and true to the best of my knowledge.

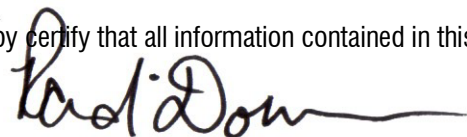
SIGNATURE OF OWNER/APPLICANT

5/24/17
Date

PROJECT STATEMENT

The Trinity Presbyterian Church has been the heart of the West University Neighborhood since it was built in 1924, with additions in 1937, 1948, 1952, 1955 and 1959. Situated along 4th Avenue and the Modern Streetcar route, between the downtown core and University of Arizona, the Trinity site is the optimal location for a responsibly dense, sustainable mixed-use (residential, office and retail) development that will enhance the neighborhood, celebrate the church's historical architectural significance and provide an ongoing income stream for the church.

We have planned a mixed-use community with market rate housing, modern office space and retail along 4th Avenue and University Boulevard. The project will co-exist with the existing Trinity Church that is on-site and will share automobile and pedestrian access as well as parking with this new mixed use project. The site will have increased permeability so that the neighborhood is no longer walled off from 4th Avenue. Special care will be taken to ensure that existing and new development within the Trinity PAD(H) is compatible with the existing historic and architectural character of the surrounding neighborhood. The development will respect, complement and be additive to the West University Neighborhood.

Our plan is to build two complementary buildings on the site - a 55 unit apartment building along 4th Avenue and 4th Street that will have ground floor retail, and a second building on the parking lot between Time Market and the Church with ground floor retail and office space on the upper two floors. There will be on-site paid parking available for the residents and office users, plus additional parking for retail patrons. In order to do this, we will demolish the 1959 education annex directly south of the 1924 church building along 4th Avenue, remove the awning currently covering the 1924 facade and restore the facade, and also move the 1918/1927 duplex on 4th Street to a new location +115' to the east of its current location. The 1924 church building and the 1918/1927 duplex are the only two contributing historic structures on the site.

This project brings many benefits to the community and neighborhood. The new buildings on site will embrace urban design best practices and sustainable building techniques (both active and passive), employ smart growth and transit oriented design principles, and while the design will be contemporary, it will be specifically compatible with the design in the neighborhood. In addition a lush desert landscape plan will transform barren parking lots into a verdant landscape replete with inviting pocket parks that the neighborhood can access and enjoy.

EXISTING AERIAL



THE
TRINITY

NEW AERIAL/SITE PLAN



THE
TRINITY

SITE PHOTOS



TRINITY CHURCH

University Blvd & 4th Avenue



TRINITY EDUCATION BUILDING

4th Avenue & 4th Street



SOUTH SITE ELEVATION

4th Street



WEST SITE ELEVATION

4th Avenue



NORTH SITE ELEVATION

University Blvd

THE
TRINITY

PRECEDENT EXAMPLES IN SURROUNDING AREA



444 E University Boulevard

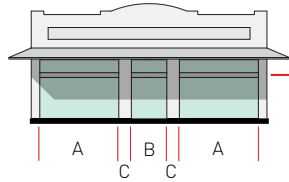

CLERESTORY
STOREFRONT



Office - University Boulevard



220 North 4th Avenue

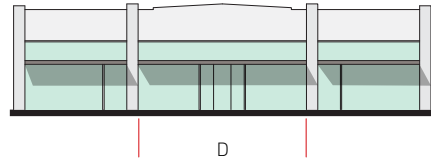

Residential - West Elevation



721 North 4th Avenue

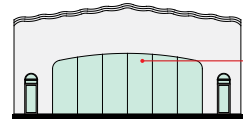

FULL WIDTH GLAZING

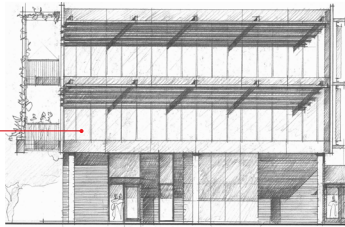

Office - South Elevation

Vertical and Horizontal Proportion

Solid and void of new building elevations are derived from adjacent historic structures in the vertical and horizontal dimension to reflect the DNA (solid/void) of historic commercial buildings along 4th Avenue and University Boulevard.

PRECEDENT EXAMPLES IN SURROUNDING AREA



720 North 6th Avenue



OFFICE BALCONY



307 East University Boulevard

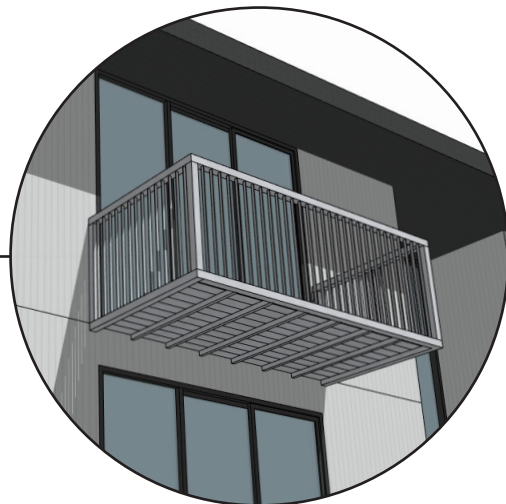

RESIDENTIAL BALCONY

Balcony

A projected balcony design that is integral to some of the multi-story buildings in the historic district is reinterpreted on the new buildings.

PRECEDENT EXAMPLES IN SURROUNDING AREA



Santa Rita Hotel 1904, Downtown Tucson



RESIDENTIAL ROOF



703 East University Boulevard



OFFICE PARAPET



444 East University Boulevard

Roof Overhang and Parapet

Roof line of the Residential building incorporates an overhang similar to multi-story buildings prevalent from the period of significance of West University. The Retail and Office buildings take a negative approach to the top of building by inseting at the high point of the parapet a similar dimension to the slight overhang cornice detail found on the Time Market and buildings along 4th Avenue.

PRECEDENT EXAMPLES IN SURROUNDING AREA



448 East 2nd Street

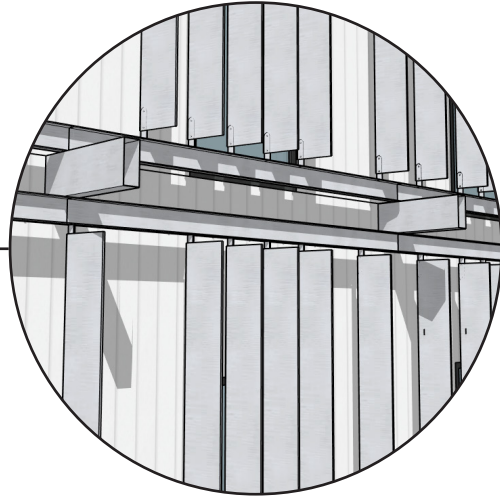

VERTICAL TRELLIS



503 East University Boulevard

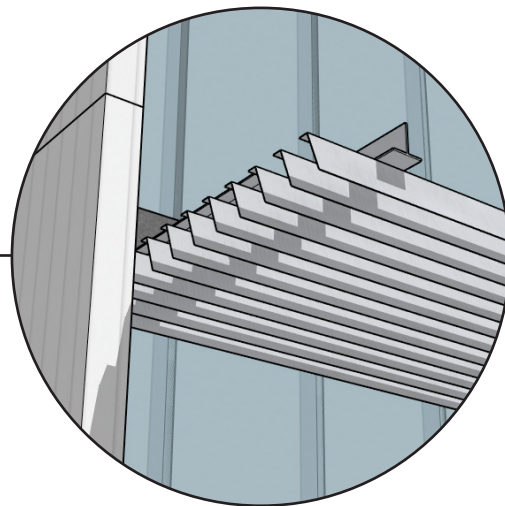

HORIZONTAL TRELLIS

Trellis and Rafter Tails

Historic trellis and rafter tails form an overlapping vocabulary of primary and secondary structure to shade and create dynamic shade and shadow. These stylistic cantilevered elements are employed on the new buildings to provide a similar approach to break down the scale of the building while shading glass and outdoor areas. New trellis shade elements are proportioned as a sub-division or multiple of the 40" window width to further continue the context of the historic surroundings and unity of old and new design.

PRECEDENT EXAMPLES IN SURROUNDING AREA



400 East University Boulevard

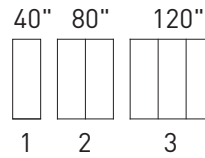

501 East 6th Street



Partial South Residential Elevation



721 East 4th Avenue

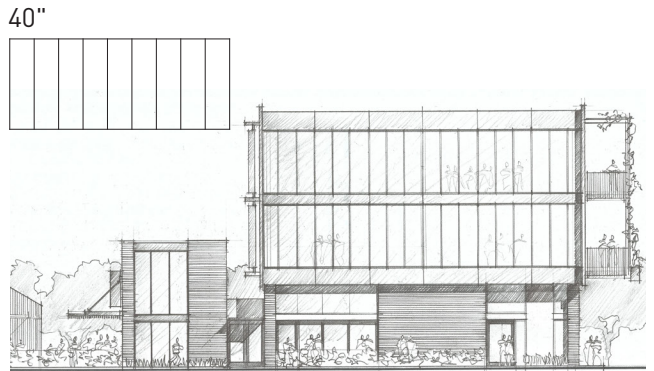

Office North Elevation

Windows and Doors

A 40 inch width for glazing and doorways on the residential, retail and office buildings is established to reference window and door widths of the historic Trinity church. This fenestration proportion is ubiquitous in the West University District and is combined to create larger widths where necessary similar to the windows on the historic Roskruege School. The office building takes this approach a step further by continuing the 40 inch glass proportion across the entire north and south facade. This approach, albeit more modern, references the large expanse of glass found on the original facade of the 1930 Chrysler dealership building directly across the street on 4th Avenue from the Trinity site.

PRECEDENT EXAMPLES IN SURROUNDING AREA



435, 441, 445 East University Boulevard

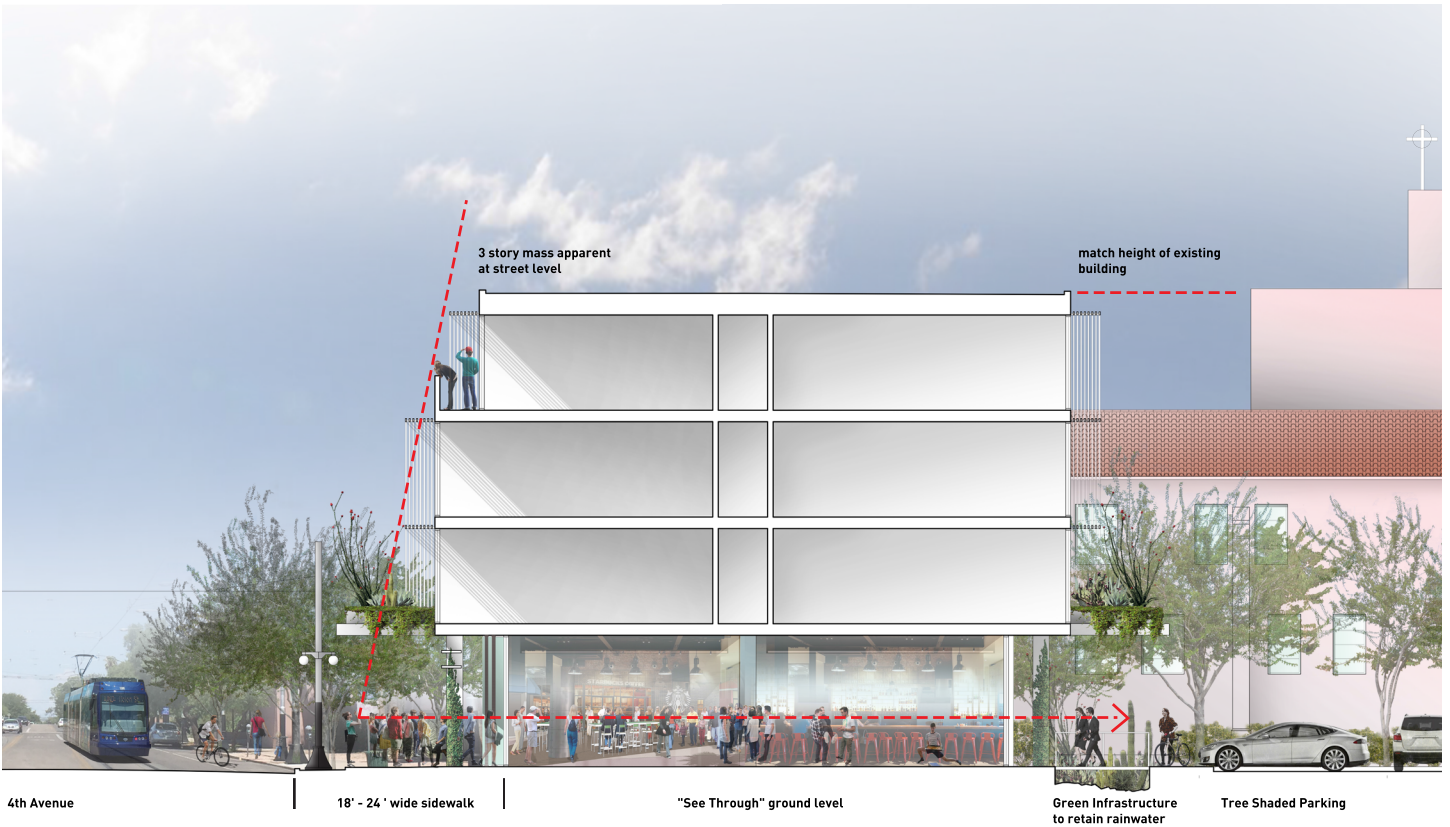

Projections and Recessions

Glass line at retail pulls back from the street along 4th Avenue, 4th Street and University Boulevard to provide shade and mass reduction while acknowledging the inset porch of the bungalow residences that surround the site.

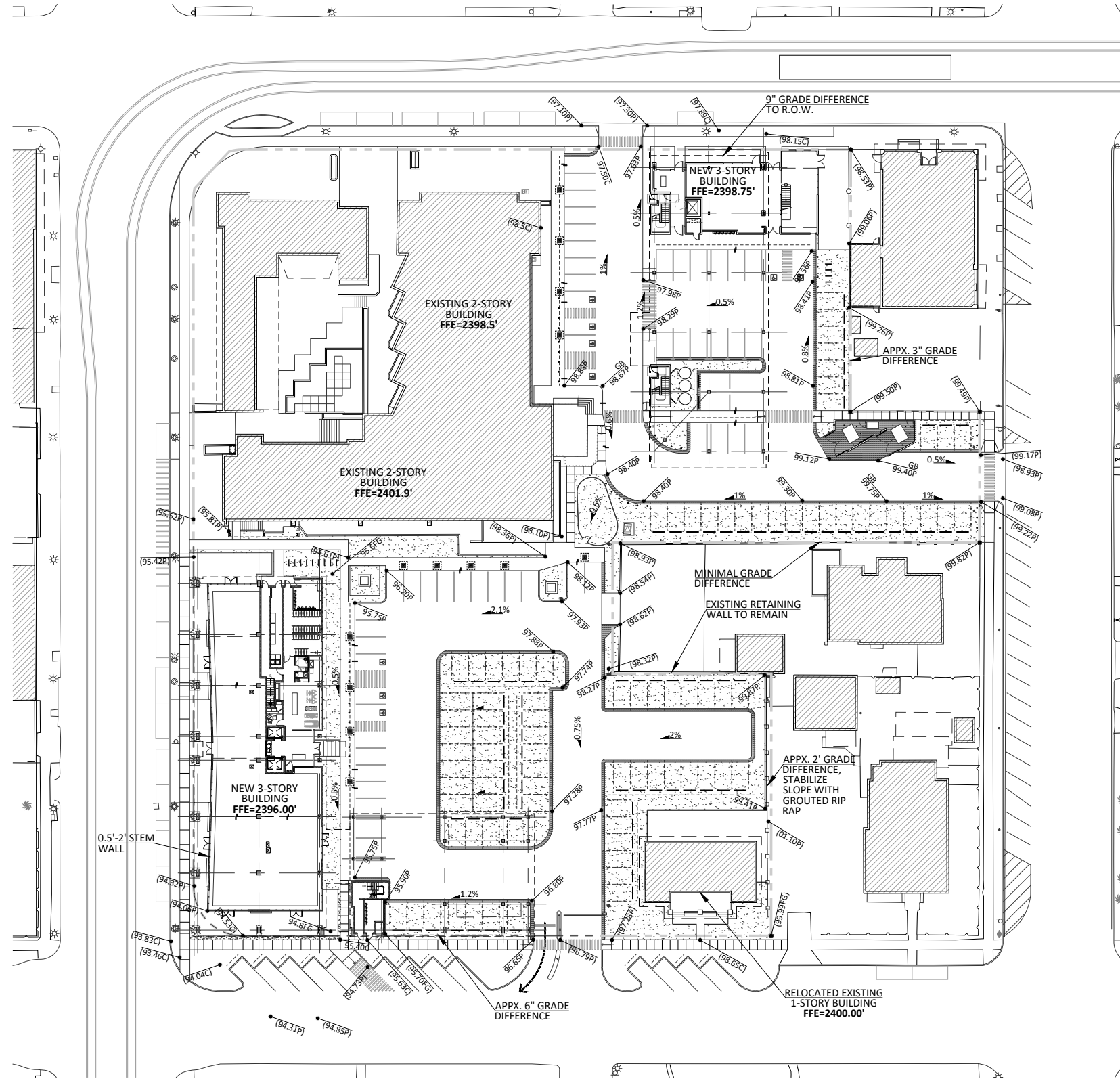

SCALE: 1"=40'
C.I. = 1 FOOT

PROJECT EARTHWORK (UNADJUSTED)(APPROXIMATE):
 TOTAL CUT 1470 CY TOTAL FILL 1180 CY COMPOSITE 290 CY (C)
 IT IS THE RESPONSIBILITY OF THE CONTRACTOR TO CALCULATE HIS OWN EARTHWORK QUANTITIES AND SUBMIT HIS BID THEREON. EARTHWORK QUANTITIES SHOWN HEREON ARE ESTIMATED FOR PERMITTING PURPOSES ONLY AND ARE NOT TO BE USED FOR BIDDING OR PAYMENT QUANTITIES.

NO.	DATE	REVISION DESCRIPTION	BY	OWNER/DEVELOPER
				R+R DEVELOP 990 EAST 17TH STREET, SUITE 100 TUCSON, ARIZONA 85719 ATTN: PH: (520) 904-4242 EMAIL:
PRELIMINARY REVIEW NOT FOR CONSTRUCTION OR RECORDING				CYPRESS PROJECT NO: 17.030 CYPRESS CIVIL DEVELOPMENT strength + sustainability 2030 east speedway boulevard suite #110 tucson, arizona 85719 ph: 520.499.2456 e: kmhall@cypresscivil.com
				SITE ADDRESS 400 EAST UNIVERSITY BOULEVARD TUCSON, ARIZONA 85705
LOCATED IN ...			PRELIMINARY GRADING PLAN for TRINITY BLOCK grading + drainage plan	
				1 OF 1



SITE PLAN

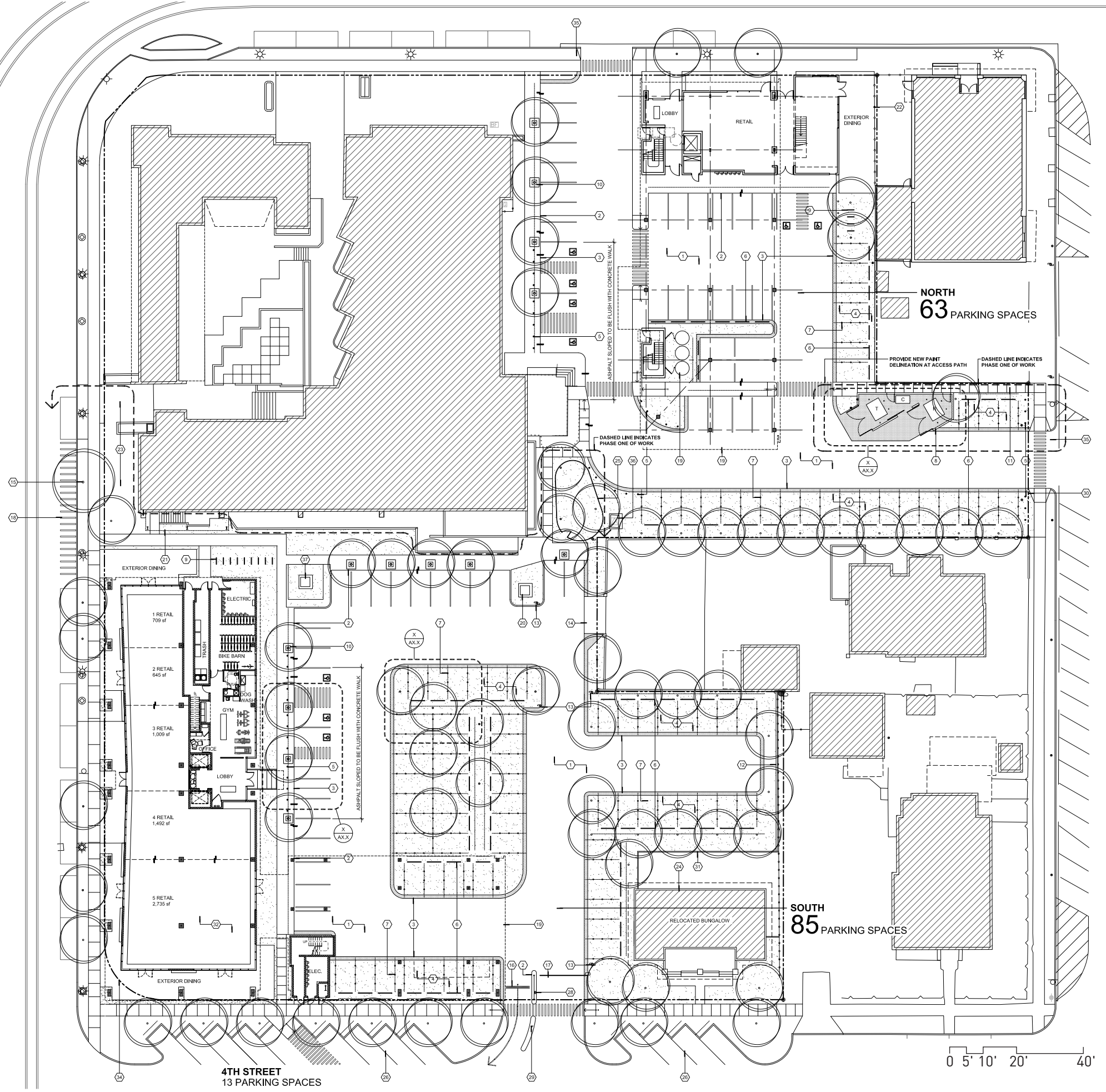

keynotes

1. ASPHALT OVER COMPACTED BASE COURSE
2. 6" HIGH RAISED CONCRETE CURB
3. FLUSH CONCRETE CURB 4" THICK x18" WIDE
4. STABILIZED DECOMPOSED GRANITE AT PARKING SPACES WITH LANDSCAPE AND DECOMPOSED GRANITE EVERYWHERE ELSE
5. 7" O.D. X 3/16" WALL THICKNESS ROUND STEEL TUBING BOLLARD AT 5' O.C. MAXIMUM. CAP TOP WITH 3/16" THICK FLATSTOCK WELD AND GRIND SMOOTH ALL AROUND. SEE DETAIL
6. 3" ROUND X .216 WALL STEEL PIPE WHEEL STOP WITH TWO 3/4" x 2-1/2"x12" BAR STOCK MOUNTING PLATES (CUT TO SHAPE OF PIPE AND WELD ALL AROUND) INTO CONCRETE FOOTING. SEE DETAIL
7. 6" DIAMETER X 1/4" STEEL PARKING DIVIDER INDICATOR (LASER CUT) MOUNTED TO #6x8" REBAR SET IN CONCRETE IN GROUND. SEE DETAIL
8. 8" CMU x 6" HIGH TRASH, RECYCLE, COMPOST ENCLOSURE. PROVIDE B-DECK GATES WITH TUBESTEEL OUTER FRAMES
9. BIKE RACK: GALVANIZED, IN-GROUND MOUNT, "HORSESHOE BIKE RACK" MODEL: 543-1094 WWW.THEPARKCATALOG.COM
10. 48" X 48" STEEL TREE GRATE, "IRONSMTIH, METRO TREE GRATE" WITH 1/2" SLOTS. HTTP://WWW.IRONSMITH.CO/TREE-GRATES-METRO.HTM
11. EXISTING CONCRETE WALK TO REMAIN OR BE RECONSTRUCTED TO MATCH ORIGINAL
12. 8" CMU RETAINING WALL WITH MAXIMUM 2'-4" GRADE DIFFERENTIAL. PROVIDE 4'-6" HIGH OPAQUE FENCING AT TOP OF WALL
13. EXISTING POWER POLE TO REMAIN. VERIFY WITH ELECTRICAL ENGINEER IF POLE SHALL REMAIN
14. EXISTING DRIVE AND ACCESS TO ADJACENT PROPERTY TO REMAIN
15. EXISTING TREE TO REMAIN
16. COBRA EZ, 9' LENGTH EXIT ONLY TRAFFIC SPIKES. HTTP://WWW.SECURE-LANE.COM/TRAFFIC-SPIKES.HTML
17. VEHICLE BARRIER GATE AND OPERATOR, APOLLO NICE M-BAR BARRIER GATE OR EQUAL, WWW.WHOLESALEPARKINGSYSTEM.COM
18. ON STREET LOADING ZONE
19. DASHED LINE INDICATES BUILDING ABOVE
20. EXISTING CHURCH WATER COOLER TOWER TO REMAIN
21. NEW SUPPORT FOR EXISTING ROOF AND A/C UNIT. RE-PURPOSE SHADE PANELS FROM FROM EXISTING EDUCATION BUILDING. EXPANDED / SHAPED METAL SHALL PROVIDE ARMATURE FOR VINES
22. EXISTING TIME MARKET COURTYARD METAL FENCE AND TRELIS ABOVE
23. SEE DEMOLITION DRAWINGS (DATED 9.22.2015) FOR SCOPE OF DEMOLITION WORK AT CHURCH AND EDUCATION BUILDING. GC SHALL PROVIDE BUDGET NUMBERS TO REPAIR AND CLOSE UP EXISTING BUILDING/HISTORIC FAÇADE WHERE CUTS ARE MADE INTO EXISTING FABRIC OF BUILDING
24. RELOCATE BUNGALOW FROM ADJACENT PROPERTY TO NEW LOCATION (MOVE EAST +/-115') SEE AS-BUILT DRAWINGS DATED 4.4.2017. BUNGALOW SHALL BE RETURNED TO ITS HISTORIC PLAN AND CONFIGURATION TO EXCLUDE ADDITIONS TO NORTHEAST SIDE. BUNGALOW SHALL HAVE ITS OWN POWER, CABLE, PHONE, WATER AND SEWER CONNECTIONS WHERE POSSIBLE.
25. AREA FOR DOG PARK. PROVIDE TUBESTEEL 3X3 OUTER FRAME WITH WELDED WIRE 1X1 INFILL PANEL. CARRY WELDED WIRE MINIMUM 4" BELOW FINISH GRADE INTO 6"x6" FLAT CONCRETE CURB.
26. NEW DIAGONAL PARKING IN RIGHT-OF-WAY PER COT STANDARDS.
27. OPTIONAL WATER HARVESTING SYSTEM FOR OFFICE BUILDING. PROVIDE 3'-6" DIAMETERX10' HIGH CORRUGATED CULVERT TANKS WITH SOLID CAP AND 3" OVERFLOW PIPE TO LANDSCAPE. WET SET TANKS INTO 16" THICK CONCRETE FOUNDATIONS AND LINK ALL THREE TANKS
28. KEY PAD ACCESS CONTROLLER
29. "RIGHT TURN ONLY" SIGNAGE
30. "LEFT TURN ONLY" SIGNAGE
31. 5'-6" HIGH OPAQUE FENCE: CORRUGATED METAL HORIZONTAL MOUNTED TO 3X3X16 GAGE TUBE STEEL UPRIGHTS AT 5'-0" O.C.
32. INTERIOR CONCRETE FLOOR PART OF TENANT IMPROVEMENT
33. 4'-6" STEPS
34. CORNER OF SITE CURRENTLY OWNED BY THE CITY OF TUCSON SHALL BE ACQUIRED BY DEVELOPER OR DEFINE A VERTICAL EASEMENT IN ORDER TO BUILD OUT THE CORNER OF THE BUILDING AS INDICATED
35. CIVIL ENGINEER TO PURSUE A T.S.M.R. TO ALLOW EXISTING ACCESS TO REMAIN VERSUS 25' RADIUS
36. EXISTING ELECTRICAL TRANSFORMER TO REMAIN AND SERVICE OFFICE BUILDING

square footages gross

north site	office	retail
3rd floor	9,060 sf	
2nd floor	9,060 sf	466 sf
1st floor	871 sf	2,319 sf
total	18,851 sf	2,785 sf
GROSS	21,776 sf	

south site	residential	retail
4th floor	16,263 sf	
3rd floor	17,981 sf	
2nd floor	17,981 sf	
1st floor	3,218 sf	6,590 sf
total	55,443 sf	6,590 sf
GROSS	62,033 sf	

THE
TRINITY

LANDSCAPE / SITE PLAN

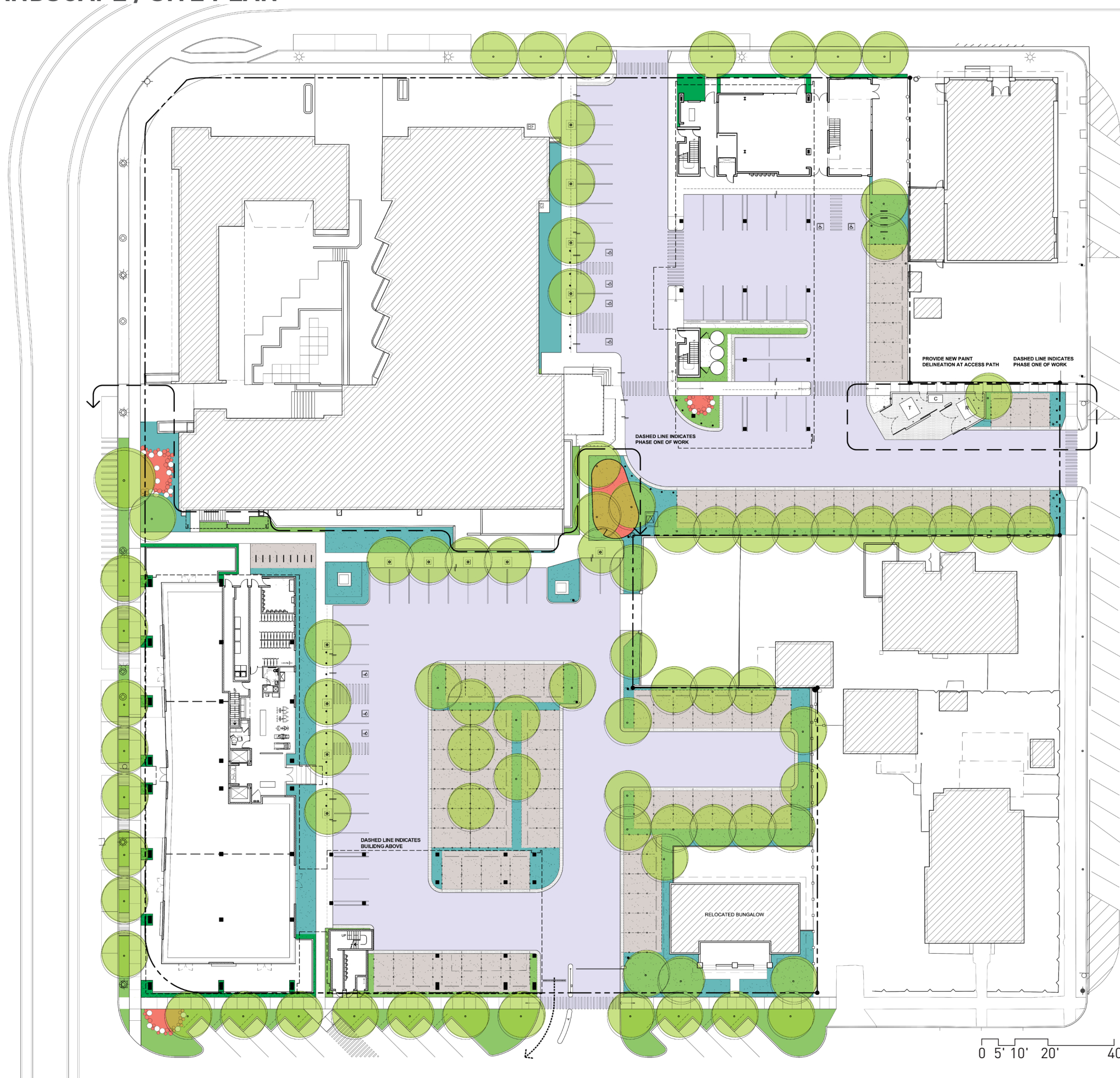

Trinity Mixed Use

Streetscape and Landscape of the Trinity Mixed Use project will play a key role in defining a memorable and ecologically sustainable project. The experience of the block will be greatly enhanced with a landscape approach that is grounded in integrating with nature. All landscape will be selected from the Arizona Department of Water Resources "Low Water Use/Drought Tolerant Plant List" as modified by the Trinity PAD(H) and the IID Design Standards. The site will be re-contoured to allow maximum use of rainwater for foliage. Hardscape will combine with an intriguing palette of low water use plantings to promote an environment that is safe, walkable, vibrant, accessible and attractive.

- Trees**
 Low water use trees will be generously employed throughout the site to maximize shade and integrate with the following: depressed retention areas, stabilized decomposed granite parking areas, in-between and at edges of parking as well as providing memorable, functional streetscape along University Boulevard, Fourth Avenue and Fourth Street.
- Shrubs, Succulents and Cacti**
 Sonoran Desert shrubs, succulents and cacti will create different sizes, forms, textures and color to enliven the landscape and provide a much needed micro-climate at pedestrian walkways through the site. Selection of plants will bring the desert back into the Trinity site with low-water use species to celebrate our unique natural environment.
- Ground Cover**
 Desert adapted ground cover, perennials and annuals will unify the landscape and provide: soil stabilization, minimize dust, shade bare surfaces and create visual interest with texture and color.
- Vertical Landscape: Vines and Living Fence**
 Vertical landscape of multi-color, multi-scent vines will grow up masonry and concrete walls and columns. Outdoor dining areas will be edged by living fence with a steel latticed structure to allow vines to grow up and across this vertical frame.
- Pocket Park**
 Where the site configuration allows, a pocket park will be integrated with shade, seating and lush desert landscape to provide an attractive, safe area that supports social activity and sustainability.
- Existing/New Sidewalks**
 Existing WPA (Works Progress Administration) sidewalks that border the site shall remain intact and be repaired/replaced where necessary. New concrete will match existing in color but differentiate slightly in texture to provide a delineation between old and new.
- Decomposed Granite/Rock**
 Stabilized decomposed granite/rock at parking areas with 6" diameter x 1/4" steel parking divider indicators. Areas not allocated to parking will be depressed for water retention and landscape.
- Concrete Edge**
 18" wide flat concrete edge curb as transition between decomposed granite and asphalt.
- Asphalt**
 Asphalt for drive lane and parking spaces for ADA and ease of pedestrian access.

THE
TRINITY

FLOOR PLANS

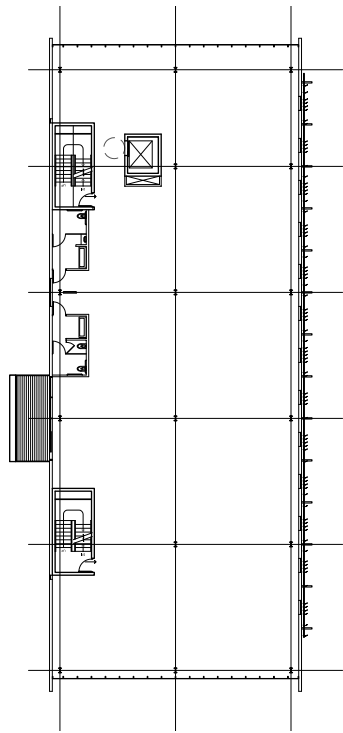

LEVEL TWO

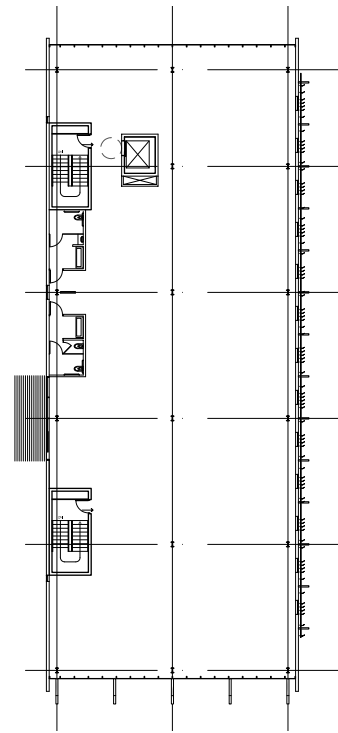

LEVEL THREE

OFFICE PLANS

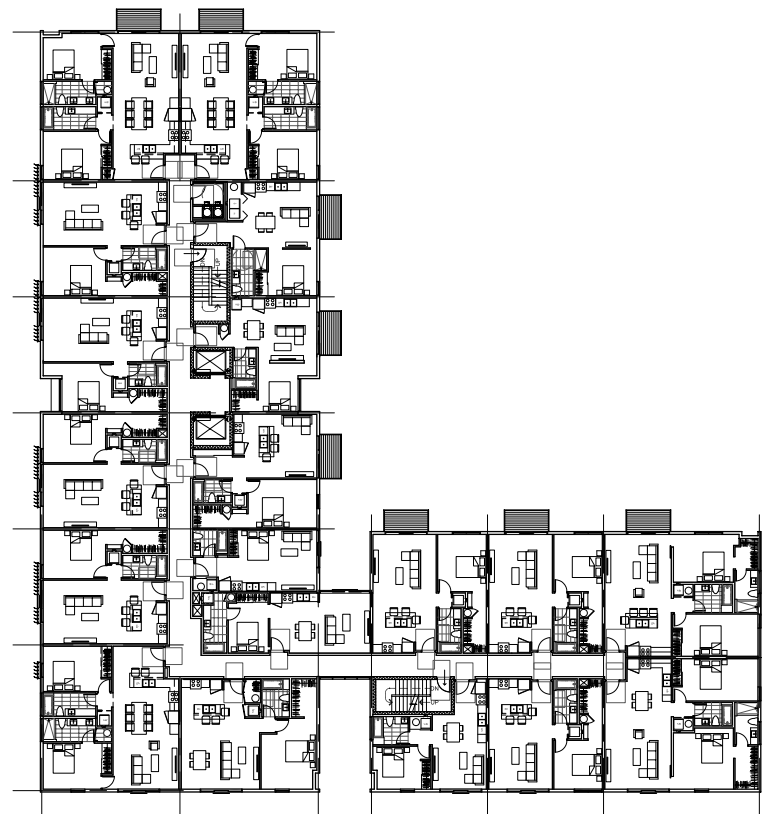

LEVEL TWO

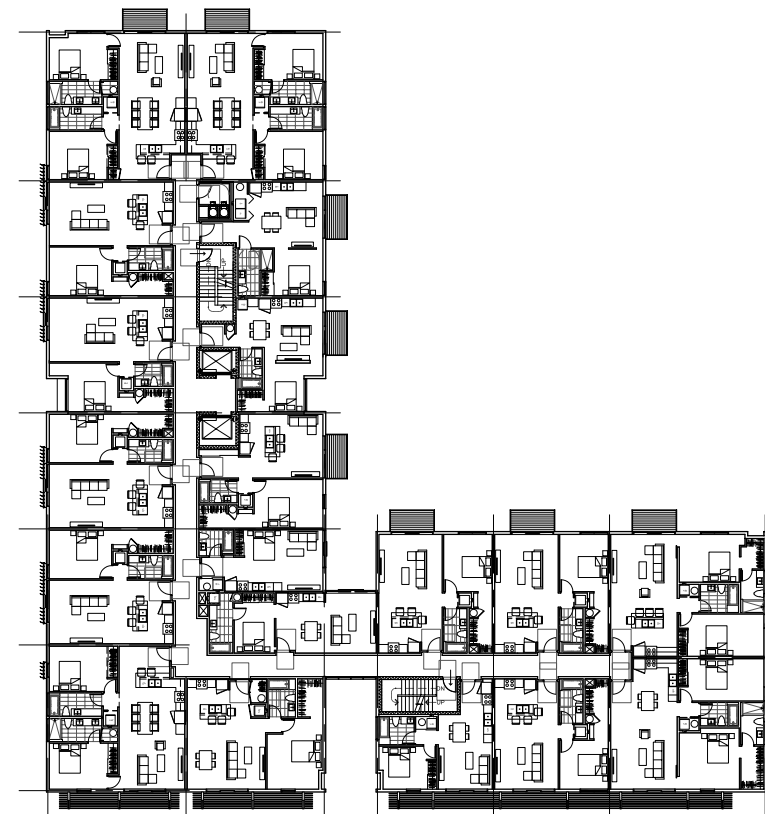

LEVEL THREE



LEVEL FOUR

RESIDENTIAL PLANS

THE
TRINITY

OFFICE / RETAIL ELEVATIONS

1. CAST IN PLACE CONCRETE COLUMN
2. INTEGRAL COLOR, DARK GRAY EXPOSED AGGREGATE BLOCK
3. OFFSET, DARK ANODIZED STOREFRONT WALL SYSTEM, DUAL GLAZED LOW-E GLASS
4. CORRUGATED METAL, PRE-FINISHED-A, DEEP PROFILE
5. FLAT METAL PANEL, PRE-FINISHED-A COLOR
6. HOLLOW METAL DOOR AND FRAME
7. BALCONY ELEMENT AT 2ND AND 3RD FLOOR WITH WEST PLANTER AND VERTICAL AIRCRAFT CABLES TO HOLD VINES, FLATSTOCK RAILING AT 3 SIDES, PRE-WEATHERED GALVANIZED FINISH
8. VERTICAL SHADE PANELS AT EAST ELEVATION, PRE-WEATHERED GALVANIZED FINISH
9. HORIZONTAL SHADE PANELS AT SOUTH ELEVATION, PRE-WEATHERED GALVANIZED FINISH
10. FLAT METAL PANEL AT UNDERSIDE OF SOFFIT FROM EXTENT OF OUTER WALL TO INSIDE OF GLASS LINE, MATCH DARK ANODIZED COLOR
11. HORIZONTAL SHADE PANEL AT RETAIL, TENSION STRUT BACK INTO MASONRY, PRE-WEATHERED GALVANIZED FINISH
12. STEEL SHADE BOX AT LARGE PICTURE WINDOW, PRE-WEATHERED GALVANIZED FINISH
13. SMOOTH TROWEL STUCCO
14. HORIZONTAL SHADE PANELS, PRE-WEATHERED GALVANIZED FINISH
15. RAINWATER HARVESTING TANKS UNDER BUILDING

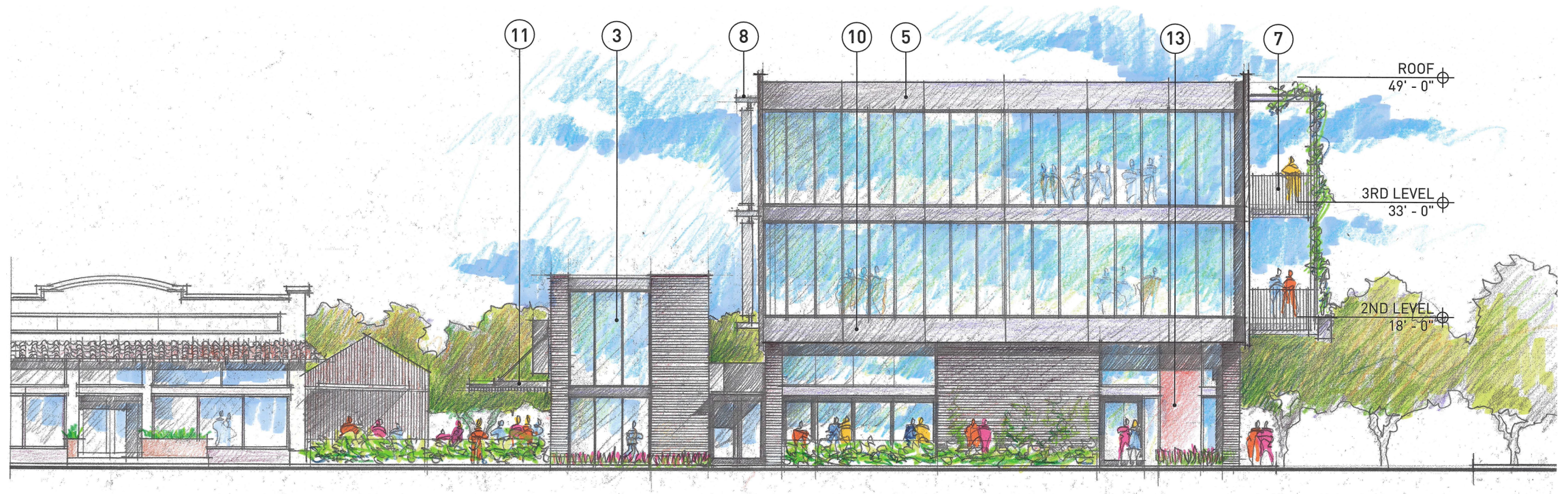

NORTH ELEVATION

University Boulevard



Concrete



Block



Corrugated Metal - A

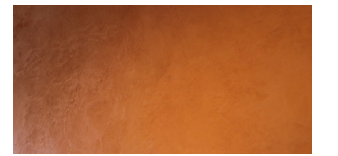

Stucco

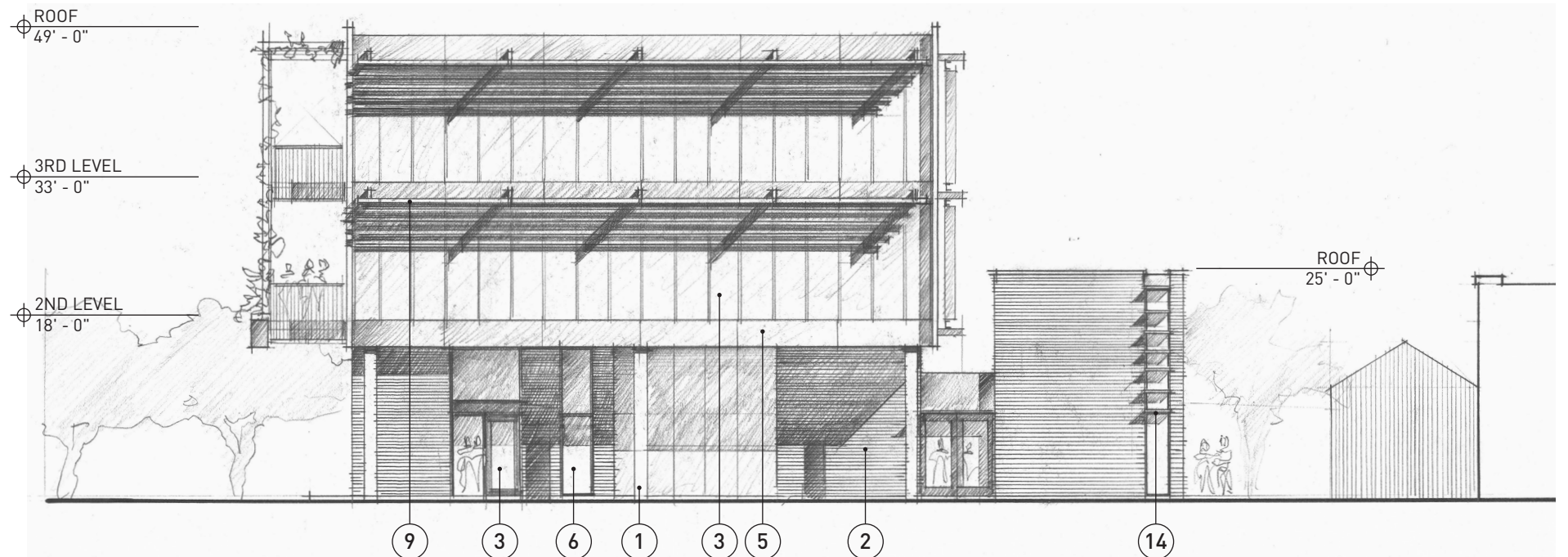

SOUTH ELEVATION



THE
TRINITY

OFFICE / RETAIL ELEVATIONS

1. CAST IN PLACE CONCRETE COLUMN
2. INTEGRAL COLOR, DARK GRAY EXPOSED AGGREGATE BLOCK
3. OFFSET, DARK ANODIZED STOREFRONT WALL SYSTEM, DUAL GLAZED LOW-E GLASS
4. CORRUGATED METAL, PRE-FINISHED-A, DEEP PROFILE
5. FLAT METAL PANEL, PRE-FINISHED-A COLOR
6. HOLLOW METAL DOOR AND FRAME
7. BALCONY ELEMENT AT 2ND AND 3RD FLOOR WITH WEST PLANTER AND VERTICAL AIRCRAFT CABLES TO HOLD VINES, FLATSTOCK RAILING AT 3 SIDES, PRE-WEATHERED GALVANIZED FINISH
8. VERTICAL SHADE PANELS AT EAST ELEVATION, PRE-WEATHERED GALVANIZED FINISH
9. HORIZONTAL SHADE PANELS AT SOUTH ELEVATION, PRE-WEATHERED GALVANIZED FINISH
10. FLAT METAL PANEL AT UNDERSIDE OF SOFFIT FROM EXTENT OF OUTER WALL TO INSIDE OF GLASS LINE, MATCH DARK ANODIZED COLOR
11. HORIZONTAL SHADE PANEL AT RETAIL, TENSION STRUT BACK INTO MASONRY, PRE-WEATHERED GALVANIZED FINISH
12. STEEL SHADE BOX AT LARGE PICTURE WINDOW, PRE-WEATHERED GALVANIZED FINISH
13. SMOOTH TROWEL STUCCO
14. HORIZONTAL SHADE PANELS, PRE-WEATHERED GALVANIZED FINISH
15. RAINWATER HARVESTING TANKS UNDER BUILDING

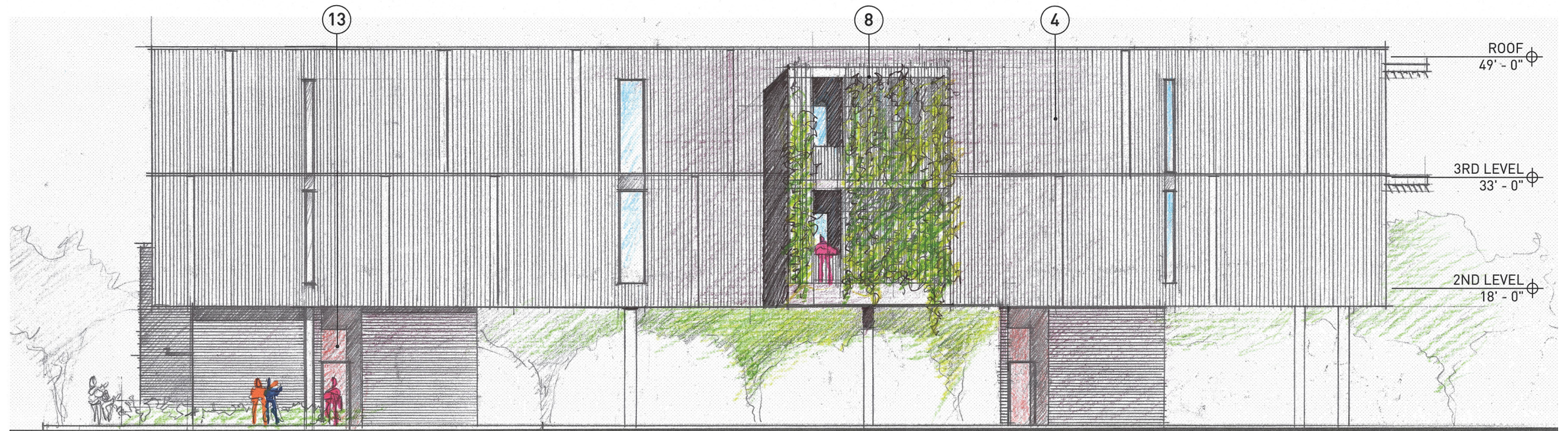

WEST ELEVATION

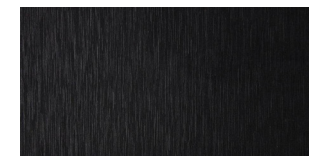

Dark Anodized

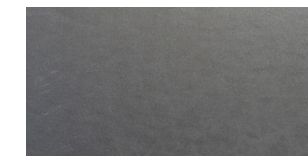

Flat Panel



Pre Weathered Galvanized



Landscaping

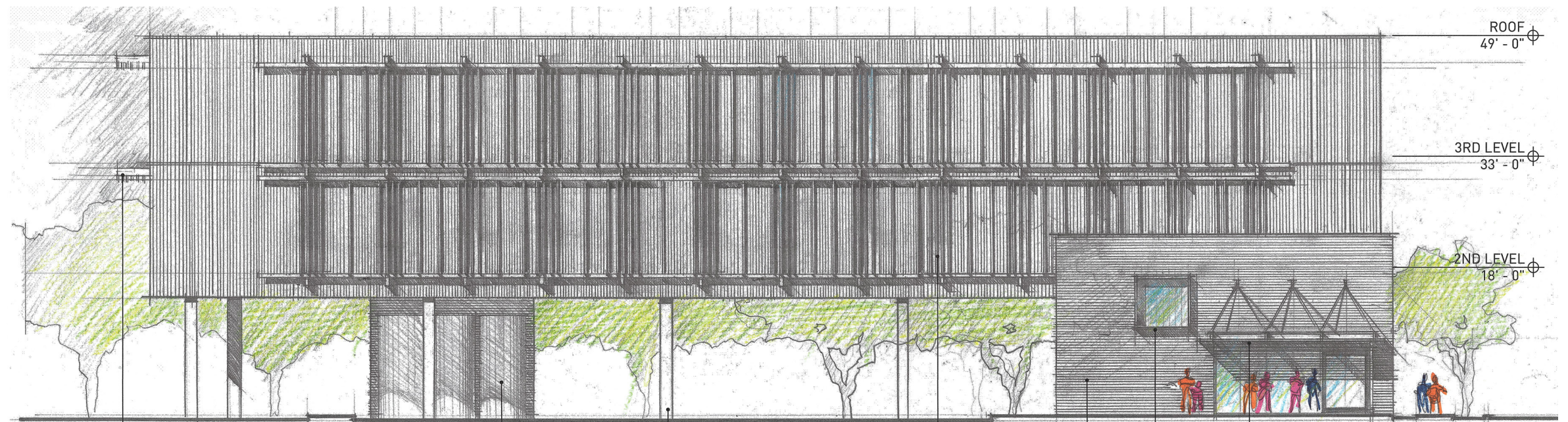

EAST ELEVATION



THE
TRINITY

RESIDENTIAL / RETAIL ELEVATIONS



NORTH ELEVATION

University Boulevard

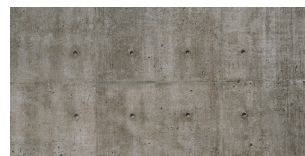

Concrete



Block

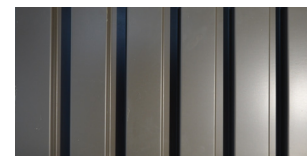

Corrugated Metal - A



Corrugated Metal - B



SOUTH ELEVATION

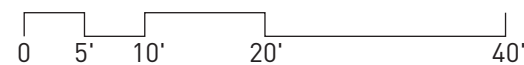

1. CAST IN PLACE CONCRETE COLUMN
2. INTEGRAL COLOR, DARK GRAY EXPOSED AGGREGATE BLOCK
3. OFFSET, DARK ANODIZED STOREFRONT WALL SYSTEM, DUAL GLAZED LOW-E GLASS
4. CORRUGATED METAL, PRE-FINISHED-A, DEEP PROFILE
5. CORRUGATED METAL, PRE-FINISHED-B, THIN PROFILE
6. FLAT METAL PANEL FASCIA AND SOFFIT, PRE-FINISHED-A COLOR
7. HOLLOW METAL DOOR AND FRAME
8. EXTERIOR WALL MOUNTED BALCONY, PRE-WEATHERED GALVANIZED FINISH
9. EXTERIOR WALL MOUNTED JULIET BALCONY, PRE-WEATHERED GALVANIZED FINISH
10. VERTICAL SHADE PANELS, PRE-WEATHERED GALVANIZED FINISH
11. HORIZONTAL SHADE PANELS, PRE-WEATHERED GALVANIZED FINISH
12. HANGING PLANTER, PRE-WEATHERED GALVANIZED FINISH
13. WINDOW/SLIDER SYSTEM, DARK ANODIZED FINISH
14. STEEL PLANTER, PRE-WEATHERED GALVANIZED FINISH, WITH VERTICAL AIRCRAFT CABLES TO HOLD VINES
15. FLAT METAL PANEL AT UNDERSIDE OF SOFFIT FROM EXTENT OF OUTER WALL TO INSIDE OF GLASS LINE, MATCH DARK ANODIZED COLOR
16. IMAGE SHOWN DEPICTS A PLACEHOLDER FOR ART THAT WILL BE INSIDE OF THE GLASS LINE

RESIDENTIAL / RETAIL ELEVATIONS



WEST ELEVATION



Dark Anodized



Flat Panel



Pre Weathered Galvanized



Landscaping



EAST ELEVATION

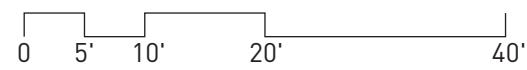

THE
TRINITY

IID DESIGN STANDARDS

Approved May 15th, 2017

New building design within the Trinity PAD(H) district will demonstrate compliance with the following:

1. Lighting

- a. Lighting strategies shall minimize glare and light trespass, conserve energy, and promote safety and security.
- b. All area lights, including streetlights and parking area lights shall be full cut-off fixtures.
- c. Sources of lighting shall be recessed and shielded so that the bulb itself is concealed from public right-of-way view.
- d. Site will be in compliance with the dark sky ordinance.

Lighting for the project is per requirements listed above.

2. Building Materials and Colors

- a. Building materials should be chosen for their tactile effects and used in a contrasting manner: e.g., rough surfaces against smooth, vertical patterns against horizontal, etc. and used to reduce the apparent scale of the building.
- b. Building materials should be chosen for integral colors and their visual and physical permanence in the Sonoran Desert.
- c. Facades shall be constructed of high quality materials including the following:
 - Masonry, such as brick, stone, cast concrete, cast stone, glass fiber reinforced concrete, terra-cotta cladding, and concrete masonry units.
 - Architectural metals, such as metal panel systems, metal sheets with expressed seams, metal-framing systems, or cut, stamped or cast, ornamental metal panels.
 - Glass and/or glass block.
 - Modular panels, such as cement board systems, exterior insulation finish systems, and stucco, provided that exterior insulation finish systems and stucco shall be limited to less than 50% of the building facade at the ground floor of the buildings facing public streets. There shall be no limit to the area of exterior insulation finish systems and stucco above the ground floor.
- d. Building materials used at the lower floors adjacent to the street frontage should be durable and respond to the character of the pedestrian environment through such qualities as scale, texture, color and detail.
- e. Accent colors should be used consistently throughout the building: in signage, architectural features, lighting, window frames, doors and accent walls.
- f. Colors and materials that reflect glare should not be used in large quantities.

Building materials and colors on the project are per the requirements listed above.

3. Architectural Elements and Features

- a. Architectural elements such as balconies, outdoor stairs, ornaments and surface details, such as screening, cladding and fenestration, shall be used to enhance the architectural style of the building.
- b. Architectural elements should take into consideration appropriateness of use, scale, proportion, color and texture.
- c. Architectural details shall be carefully integrated in the concept design of the building.
- d. There shall be a clear visual distinction between the ground floor and upper floors.
- e. A single plane of street-facing facade may not exceed 20 feet without architectural detail.
- f. Areas for outdoor vending and small group gathering are encouraged. The areas should be delineated with hardscape materials, grade change or vegetation.

Architectural Elements and Features are per the requirements listed above.

IID DESIGN STANDARDS

4. Building Articulation

- a. Articulate building facades at entrances and between retail spaces to create areas of exterior patio and engagement.
- b. Public art that is integrated into the design scheme is encouraged. Art designed and manufactured locally is encouraged (e.g. sculpture art).

Building Articulation is per the requirements listed above.

5. Doors

- a. Doors at primary pedestrian entrances must be shaded or protected from the weather.
- b. Doors must be clearly identifiable.
- c. Doors must be safe, secure, and universally accessible.
- d. Canopies at storefronts, where provided, may be used as a design element and may incorporate signage.
- e. Storefronts shall be integrated with the sidewalk design and treatment.

Doors on the project are per the requirements listed above.

6. Windows and Glazing

- a. Glazing shall provide, where possible, a visual connection through either side of the window.
- b. Window size, proportion and pattern should relate to unit types and room layouts, and should be used to reinforce organized patterns of scale and variety within the building facade.
- c. Mixed-use developments shall utilize a variety of ratios of clear to opaque surfaces (i.e., glass to wall) to reflect the different uses within the building. In general, residential uses should have less glass-to-wall and commercial uses greater glass-to-wall.

Windows on the project are per the requirements listed above.

7. Building Facades

The street-facing building facade at the base shall include at least two of the following elements:

- a. Trellis or vertical garden element with minimum 50% live vegetation cover.
- b. Artwork (e.g. public mural, or custom-designed panel).
- c. Outdoor dining or gathering patio, delineated by a low wall, low fence, planters, slight change in elevation, or other buffer devices.
- d. Distinctive architectural lighting element.
- e. Shade structure.
- f. Changes to building plane such as indentations, textures, or accent materials.
- g. Buildings shall provide windows, window displays, or visible activity on the ground floor for at least 50 percent of frontage

Building facades on the Trinity Mixed Use project include items c and f per the list above.

8. Streetscape

The streetscape along University Boulevard and Fourth Avenue shall be designed to promote continuity of streetscape design along each of those streets. Existing sidewalk widths shall be maintained so as to provide effective, accessible, connectivity to adjoining properties. Sidewalks may be widened to accommodate a project's design characteristics. Where no sidewalks exist, sidewalks shall be provided. Outdoor seating and dining areas and landscaping may be located in the sidewalk area where safe and effective sidewalk width around the design feature can be provided. In addition, the streetscape should be guided by the following principles:

- a. **Memorable:** Streetscape should be designed to give the city and the West University Neighborhood a recognizable image and provide a means of orientation and understanding of the city.
- b. **Support diverse public life:** Provide opportunities for diverse experiences and encourage people to spend time engaging in social and recreational activities.
- c. **Vibrant places for commerce:** Streetscapes should be designed and managed as attractive and exciting destinations that encourage residents and visitors to walk to and use local shopping areas, rather than to drive to regional shopping centers.

IID DESIGN STANDARDS

- d. **Promote human use and comfort:** Streetscapes should be designed to prioritize the everyday needs of people and to support human comfort and enjoyment.
- e. **Promote healthy lifestyles:** Streetscapes should promote healthy lifestyles by encouraging walking to daily and occasional destinations, minimizing pedestrian injuries and helping to decrease major chronic diseases related to air quality and pedestrian activity.
- f. **Safe:** Streetscapes should be designed to create a street environment that supports a high level of pedestrian safety and security.
- g. **Create convenient connections:** Streetscapes should be designed to facilitate safe, accessible, and convenient connections among major nodes, hubs, destinations, transit centers, and major land use and activity centers.
- h. **Ecologically sustainable:** Streetscapes should be designed as a green network, enhancing the City's long-term ecological functioning.
- i. **Accessible:** Streetscapes should be designed for ease of use and access to destinations for all populations, particularly those with visual or mobility impairments.
- j. **Attractive, inviting, and well-cared for:** Streetscapes should be beautiful, create an engaging visual impression, appeal to senses of sight, smell, and sound, and encourage a sense of ownership and civic pride that is reflected in streets' physical appearance and level of activity.

Streetscape along University Boulevard and Fourth Avenue is per the requirements listed above.

9. Environmentally Conscious Design Practices.

Each Development shall include five or more of the following:

- a. Provide shade for at least 70% of parking areas.
- b. Provide shade for at least 70% of pedestrian areas.
- c. Provide direct access connections from transit stops.
- d. Provide Energy Star or cool roof rated at least 0.65 reflectivity and at least 85% emissivity.
- e. Use LED outdoor lighting of less than or equal to 3600 Kelvin to comply with City of Tucson Outdoor Lighting Code.
- f. Provide shade for Short Term Bicycle Parking Facilities.
- g. Provide 100% desert-adapted plant species. Species chosen must adhere to the Arizona Department of Water Resources Tucson AMA Drought Tolerant/Low Water Use Plant List, Sonoran desert native species shall be given priority. Oleander and South American hybrid mesquite shall be prohibited.
- h. Provide solar panels on roof or shade structures.
- i. Provide green roof with at least 4" of growth medium.
- j. Provide porous concrete or permeable paving adjacent to planting areas.
- k. Provide vegetated "green walls" (covered by live plant material) or trellises.
- l. Provide high performance windows and insulation that exceed the minimum requirements of the International Energy Conservation Code.
- m. Adaptive reuse of an existing structure.
- n. Implement Car Share use or incorporate a transit stop on-site
- o. Incorporate innovative design practice such as alternative methods of energy savings or production, reduction in water use, or recycled content site paving materials.
- p. Use reclaimed water from municipal source or harvested from mechanical systems and treated for landscaping.

The Trinity Mixed Use project will include Environmentally Conscious Design Practices items c,d,e,g and j per the list above.