



Second modification request to: Increase # of dwelling units from 9 to 14, eliminate office space, reduce retail space from 4,600 SF to 1,700 SF, and change west facade and outdoor patio.

SPECIAL DISTRICTS APPLICATION

Application Stage: Pre-application [] Application [x]
Permit Activity Number: T20SA00220 Case Number: RNA-DRB-20-05 & HPZ-20-047 Date Accepted: 8/20/2021

PROPERTY LOCATION AND PROPOSED DEVELOPMENT

Project / Development Name (if applicable): 124 East Broadway

Property Address: 114 & 124 East Broadway Tucson, AZ 85701

Pima County Tax Parcel Number/s: 117-17-0030 & -0050

Current Zoning: OCR-2

Applicable Overlay/ Special Districts: [] Infill Incentive District [x] Rio Nuevo Area [] Main Gate Overlay District [] Grant Road Overlay District [] Neighborhood Preservation Zone [] Historic Preservation Zone

Neighborhood Association (if any):

PROJECT TYPE (check all that apply): Change of use to existing building [x] New building on vacant land [] New building on developed land [] New addition to existing building [] Other

Description of Proposed Use: Office, Retail/restaurant and residential

Number of Buildings and Stories/Height of Proposed Structure(s): New patio area & renovation of existing 2-story building

Site Area (sq ft): 11,135 Area of Proposed Building (sq ft): 20,565 sf existing building; patio is 1,995 sf

HISTORIC STATUS

Site is within a: Historic Preservation Zone Please List: National Register District Please List: Site is/includes: [] A contributing structure [] Non-contributing structure [] Is adjacent to a contributing structure [] Vacant

APPLICANT INFORMATION (The person processing the application and designated to receive notices):

APPLICANT NAME:

ROLE: [] Property owner [] Architect [x] Engineer [] Attorney [] Developer Other: _____

EMAIL: thadley@cypresscivil.com PHONE: 520.499.2456

ADDRESS: 2030 E Speedway Blvd Ste 110 Tucson, AZ 85719

PROPERTY OWNER NAME(S) (If ownership in escrow, please note): Julian Drew Lofts LLC, Attn Ross Rulney

PHONE: 520.850.9300

I hereby certify that all information contained in this application is complete and true to the best of my knowledge.

SIGNATURE OF OWNER/APPLICANT* [Signature] 08/13/21

*If an authorized representative is signing on behalf of the property owner, please provide a letter of authorization Date

RNA-DRB-20-05 & HPZ-20-047 (T20SA00220)
VFW Renovation - Revision Two Changes
114-124 E Broadway Boulevard

Modifications to Approved Plans

PRS notes added 09-09-21.

1. Adding 5 residential units to ground and lower levels, replacing potential office/retail lease space. Ground level retail will remain along Broadway Blvd.
2. East Elevation: asking for approval to leave existing terra-cotta façade as-is ~~but keep in place previous approval to insert roll-up glass door, decision depending on now unknown future tenant wishes.~~
3. North Elevation: no changes.
4. West Elevation: light well has been deleted and replaced with on-grade patios for ground floor residential tenants. Privacy fencing matches material and style of previously approved fencing. **Doors to replace portion of previously approved windows.**
5. West Patio: patio area has been slightly increased in size. One tree is omitted due to new fence location. Elimination of this tree does not affect sun-shade study as it is not in close proximity to the public sidewalk.
6. Public R.O.W: existing vehicular access curb cut to remain as-is. It has potential value in servicing the patio and for potential future site development. **(Not within purview of PRS review.)**



Project Statement (Rev 2, August 13, 2021)

VFW Renovation 114-124 E Broadway Boulevard

The renovation of the VFW building, located at 124 E Broadway Boulevard, will provide the City of Tucson with ~~9~~ 14 new market rate studio apartments (4 with interior lofts ~~and balconies~~), 3 with grade level outdoor patios, and an additional ~~4,600~~ 1,700 SF of ground floor retail space. ~~and a 5,950 SF garden level office suite.~~ The lower level will provide additional lease space for retail tenants and individually interconnected living space for the ground floor apartments. ~~These uses will~~ also preserve the historic appearance of the Broadway Boulevard façade while animating the highly visible west facade with large new window openings and residential balconies.

The adjacent parcel, located at 114 E Broadway Boulevard, will be combined into the VFW lot then developed as an outdoor amenity space for the associated ground floor retailer/restaurant, ~~and building residents. and office tenants.~~ This parcel will feature a secured, paved, landscaped patio ~~that is~~ connected to the VFW ~~and that~~ extends into the pedestrian right-of-way ~~that provides to provide~~ an opportunity for outdoor dining while also activating the street. Immediately to the south of the patio will be a landscaped ~~area for general use by building residents and private outdoor patios. with a light-well cut into it adjacent to the VFW. This light-well will provide daylight to the lower level floor while minimizing its impact on the site.~~ Trees, planting beds ~~planters~~ and textured pavers ~~paving~~ will create a visually appealing park-like focal point where now exists an asphalt parking lot.

The VFW Broadway façade will remain largely untouched. Existing windows will be refurbished to the extent possible but the now translucent, white glass, will be replaced with vision glass. The entrance canopy will be repaired with new lighting being the only alteration to this element.

The east façade 1st and 2nd floor windows will be refurbished to the extent possible but the now translucent, white glass, will be replaced with vision glass. Existing glass block windows will remain. The northeast corner 1st floor windows will remain with translucent glass replaced with clear vision glass. ~~The building Owner requests authorization to, in the future, these openings may be modified~~ modify this opening for the installation of a roll-up glass door ~~as was approved by the DRB and PRS review committees during the first project review. Should a future tenant wish to create this opening, it will~~ ~~to~~ enhance the indoor-outdoor connection between the street/sidewalk and the interior retail space.

Insertions into the existing west facing façade will be contemporary in appearance but take several design cues from the Broadway façade. Railing geometry is similar in scale to the existing terracotta tile panel sizes while new windows are gridded in a pattern similar to the existing windows, but at a proportionately larger scale. Finishes of new materials will be ~~painted galvanized~~ steel and natural anodized aluminum to reflect the color of existing building finishes.

The west facing studio apartments, are generous in size and include a bedroom loft. An impressive wall of glass will flood these apartments with natural daylight and provide for expansive views of the city. Finishes will be minimal to give the apartments a cool, urban vibe. **West facing ground floor apartments will have private exterior patios.**

Project Scope of Work Question Response

The IID application requests a written response to nine items. Responses are as follows:

1. *State the applicant's intention to use the IID zoning option in lieu of existing underlying zoning.*

The applicant and property owner/developer are choosing to develop the VFW project using the Rio Nuevo review process.

2. *Describe how the project is consistent with the IID purpose to create sustainable infill development.*

The IID option is intended to “encourage sustainable infill development that supports the creation of urban neighborhoods that are pedestrian and transit-oriented” and benefit major activity centers in the area and City as a whole while being compatible with existing residential and non-residential neighbors. Additionally, it is intended assist in overcoming incompatible development standards by allowing for modification of these standards.

The VFW renovation, while not using the IID zoning review option, is none the less consistent with the IID purpose. The building has sat vacant for a number of years and the adjoining parking lot site contributes little to the character of the neighborhood. The proposed new uses for the building and the transformation of the parking lot into an urban oasis will add to the economic vitality and livability of the area.

By not providing on-site parking for residents, retail or office tenants and being located immediately adjacent to the streetcar rail-line and within one city block of the bus transit terminal, the project will encourage multiple modes of transportation – walking, biking, public transit, car shares – as an alternative to cars.

The proposed mixed use of ground floor retail with uniquely designed studio apartments ~~above~~ will both provide opportunities for expanding the popular eastern downtown restaurant/entertainment district and increase the number of full-time residents to support these neighborhood venues.

3. *Describe the benefits the project will bring to the adjacent properties and the surrounding area.*

The addition of **9 14** new studio apartments will help fulfill the increasing demand for a variety of housing options within the downtown area while the garden level office space enhances the opportunity for more live/work lifestyles. As more residents live and work downtown, adjacent existing entertainment/restaurant venues will naturally benefit from the increase in population as housing is the driver for financially successful urban environments.

The project will bring approximately ~~4,700~~ **1,700** square feet of additional retail/restaurant space to Broadway Boulevard. Being proximate to several popular existing restaurants and across the street from the AC Marriott hotel, this renovated space will add to and compliment these existing uses.

Architecturally, the infill of a “missing tooth” along an urban streetscape increases the pedestrian friendliness of the neighborhood. With more people comfortably walking along a street, the sense of personal safety increases.

4. *Describe any significant adverse effects, such as those involving noise levels, glare, odors, vibration, illumination, fumes and vapors, the project will have on adjacent properties.*

The project is set within a predominately commercial zone along one of the busiest streets in downtown Tucson. Across the street is the popular AC Marriott hotel and adjacent uses include well established restaurants. The anticipated new retail/restaurant, office and residential use are the same as existing adjacent uses.

The project will have four west facing balconies overlooking the newly landscaped adjacent property. None of these overlook existing residential uses. Noise generated from these outdoor activity areas will likely be well less than the ambient noise of the existing neighborhood.

With several existing restaurants in adjacent buildings, should a restaurant tenant occupy the new commercial space, its contribution to neighborhood odors will be minimal. Noise generated by the commercial use will be predominately contained within the building and adjacent outdoor patio that is well surrounded by non-residential uses. Importantly, trash generated by the VFW building, the adjacent Julian Drew building and Carriage House will now be contained within the trash enclosure located immediately to the south of the building on the Odd Fellows property, a property ~~now owned~~ ~~seen to be owned~~ by the same owner. This will eliminate the existing refuse containers randomly placed in Arizona Avenue.

Neither the residential nor commercial uses will, after construction is complete, generate fumes, vapors or vibrations that could be considered a nuisance. Illumination levels will be consistent with those that currently exist along Broadway Boulevard. The majority of residential units are north and east facing and utilize existing window openings. The new window openings in the west facing facade are screened from the street by newly planted trees that will lessen the potential for direct glare off the windows into the roadway. All glass will be clear.

5. *Describe how the project will create a pedestrian-oriented streetscape in compliance with the Streetscape Design Standards (UDC Sec. 5.12.8.A).*

The project complies with the Streetscape Design Standards as follows:

- Architectural elements: Not applicable (existing historic building)
- Glazing: Existing fenestration pattern will not be altered along Broadway Boulevard. Existing translucent glass will be replaced with clear glass which will provide for better visual connectivity between exterior and interior.
- Façade Length: Not applicable
- Entrance Doors: Not applicable

- Ground Floor Commercial Space: The primary Broadway Boulevard frontage is 100 percent retail/commercial with opportunities to subdivide the space into smaller retail spaces. These commercial uses will encourage street level pedestrian activity.
- Sidewalks: An existing vehicular access drive will be eliminated and replaced with a paver design matching the existing streetscape. Elimination of this access drive will make for a safer pedestrian environment.
- Shade: With the addition of new plantings within the pedestrian right-of-way and building shade, the project exceeds the 50% shade requirement (410 sf / 2725 sf = 15% unshaded, 85% shaded). Percentage is measured on June 21st at 2 PM.

6. *Describe how the project will support a safe streetscape coordinated with adjoining properties.*

The existing vacant building and underutilized adjoining parking lots discourages pedestrian street-life. The newly proposed retail, office and residential uses for the VFW and the development of the adjacent parking lot into a pedestrian friendly landscaped environment will greatly enhance street activity thus creating a safer streetscape.

7. *Describe how the project will transition to adjacent existing residences and provide privacy mitigation in compliance with the Development Transition Standards (UDC Sec. 5.12.8.B).*

There are no existing single family or duplex residences abutting the project site requiring privacy mitigation.

8. *Indicate whether the project will significantly impede solar energy options to adjacent properties.*

With no addition to the building and new shade trees being planted to the north and east of adjacent properties, there will be no impact on adjacent properties.

9. *Describe the type of drought tolerant and native landscaping that will be used in the project and how it will be used to enhance the project.*

All proposed plant materials are drought tolerant once established.

End of Project Statement

AERIAL VIEW



VFW Building



Context Buildings



Context Buildings



BROADWAY BLVD

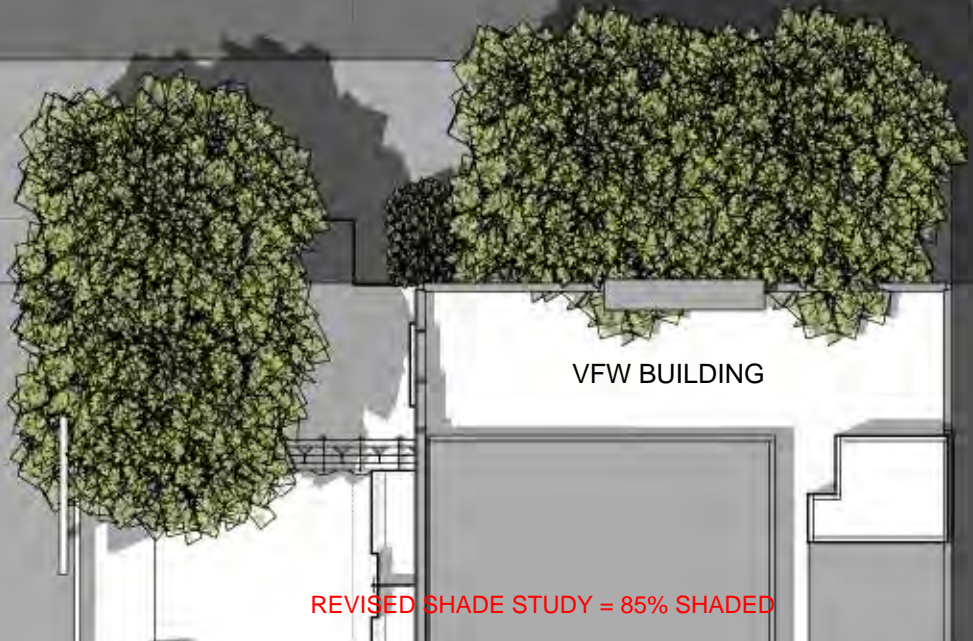

VFW BUILDING

ARIZONA AVE

REVISED SHADE STUDY = 85% SHADED

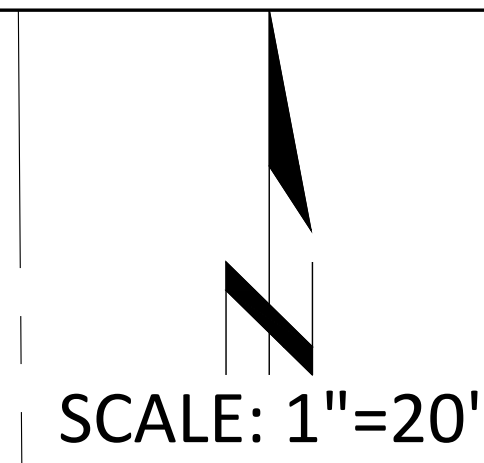
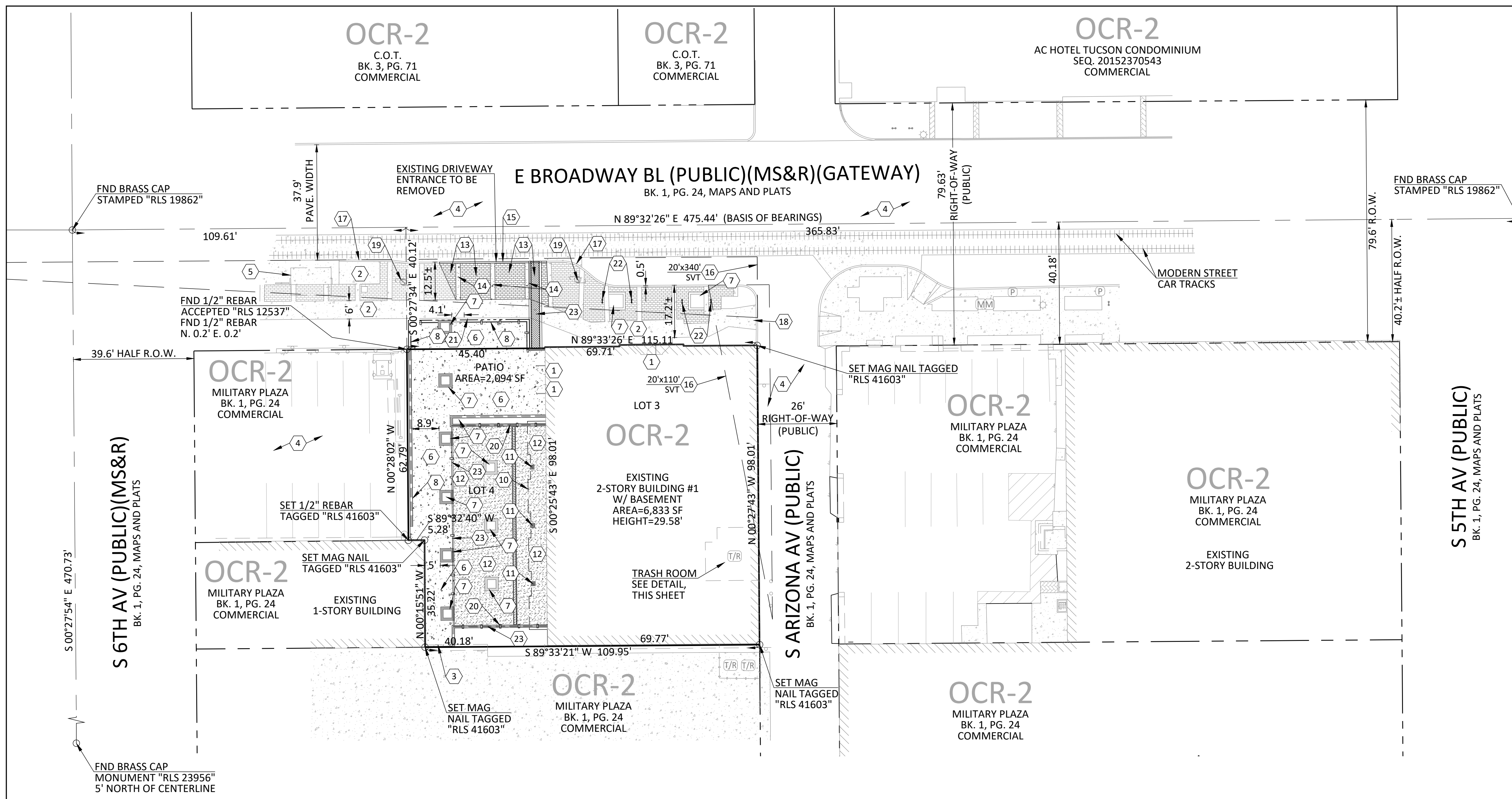

- KEYNOTES**
- 1 PRIMARY BUILDING ENTRANCE.
 - 2 EXISTING CONCRETE/SIDEWALK TO REMAIN.
 - 3 EXISTING FENCE/WALL TO REMAIN.
 - 4 EXISTING ASPHALT TO REMAIN.
 - 5 EXISTING SUN LINK SHELTER TO REMAIN.
 - 6 NEW CONCRETE SIDEWALK PER PAG DETAIL 200. SEE PLAN FOR DIMENSIONS. 2% MAX. CROSS SLOPE; 5% MAX. LONGITUDINAL SLOPE. SEE LANDSCAPE PLANS FOR FINISHES/COLORS.
 - 7 NEW LANDSCAPE PLANTER/SEAT WALL PER LANDSCAPE PLANS.
 - 8 NEW WALL/FENCE. OWNER/ARCHITECT TO PROVIDE DETAILS AND FINISHES.
 - 9 NEW RAILING/FENCING. OWNER/ARCHITECT TO PROVIDE DETAILS AND FINISHES.
 - 10 NEW BUILDING OVERHANG PER BUILDING PLANS.
 - 11 NEW BUILDING COLUMN PER BUILDING PLANS.
 - 12 NEW TURF/ROCK PER LANDSCAPE PLANS.
 - 13 NEW BRICK PAVERS TO MATCH EXISTING ADJACENT PAVERS, OR AS OTHERWISE PROVIDED BY ARCHITECT/LANDSCAPE ARCHITECT.
 - 14 NEW 1.5" WIDE CONCRETE HEADER. SEE DETAIL A, THIS SHEET. SEE LANDSCAPE PLANS FOR FINISHES/COLORS.
 - 15 NEW 6" VERTICAL CURB (TYPE 2) PER PAG DETAIL 209. SEE DETAIL B, THIS SHEET. CONNECT TO EXISTING CURB PER PAG DETAIL 211, WHERE APPLICABLE.
 - 16 SIGHT VISIBILITY TRIANGLE FOR PROPOSED DEVELOPMENT. SEE KEYNOTE FOR DIMENSIONS.
 - 17 EXISTING CURB TO REMAIN.
 - 18 EXISTING CURB ACCESS RAMP TO REMAIN.
 - 19 EXISTING LIGHT/STREET CAR POLE TO REMAIN.
 - 20 NEW RETAINING WALL PER SEPARATE PLAN AND PERMIT.
 - 21 NEW CONCRETE HEADER PER PAG DETAIL 213.
 - 22 NEW SHORT TERM BICYCLE RACK. SEE RACK DETAIL C, THIS SHEET. FOR RACK SPACING SEE DETAIL D, THIS SHEET.
 - 23 NEW SIDEWALK SCUPPER (TYPE 2) PER PAG DETAIL 205. SEE DETAIL E, SHEET 2. CONNECT TO BUILDING SUMP DRAIN OUTLETS.

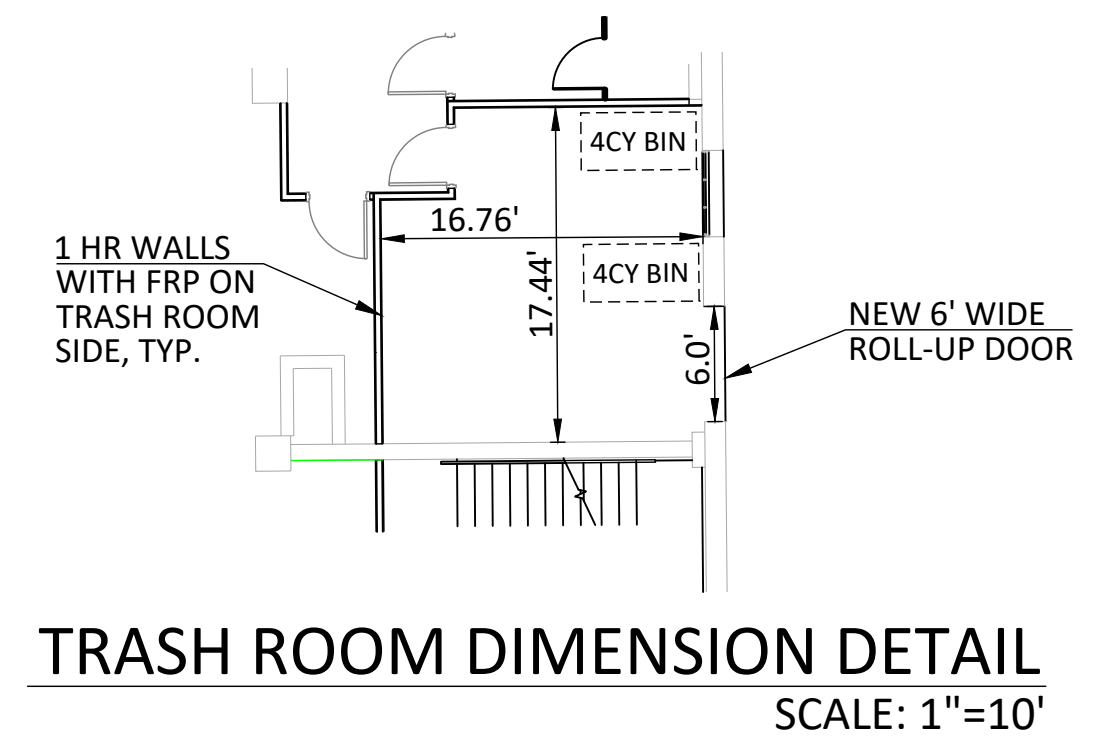
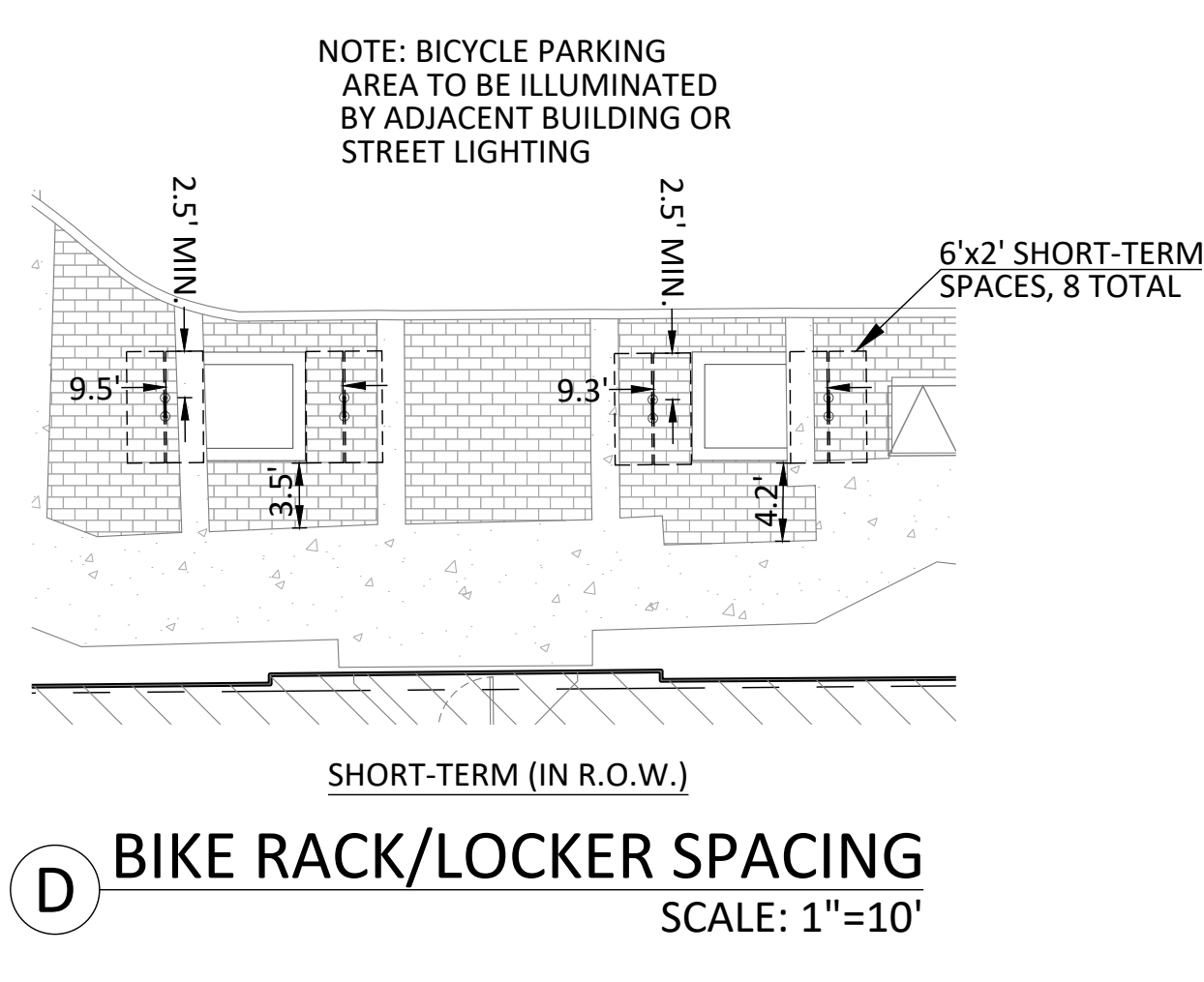
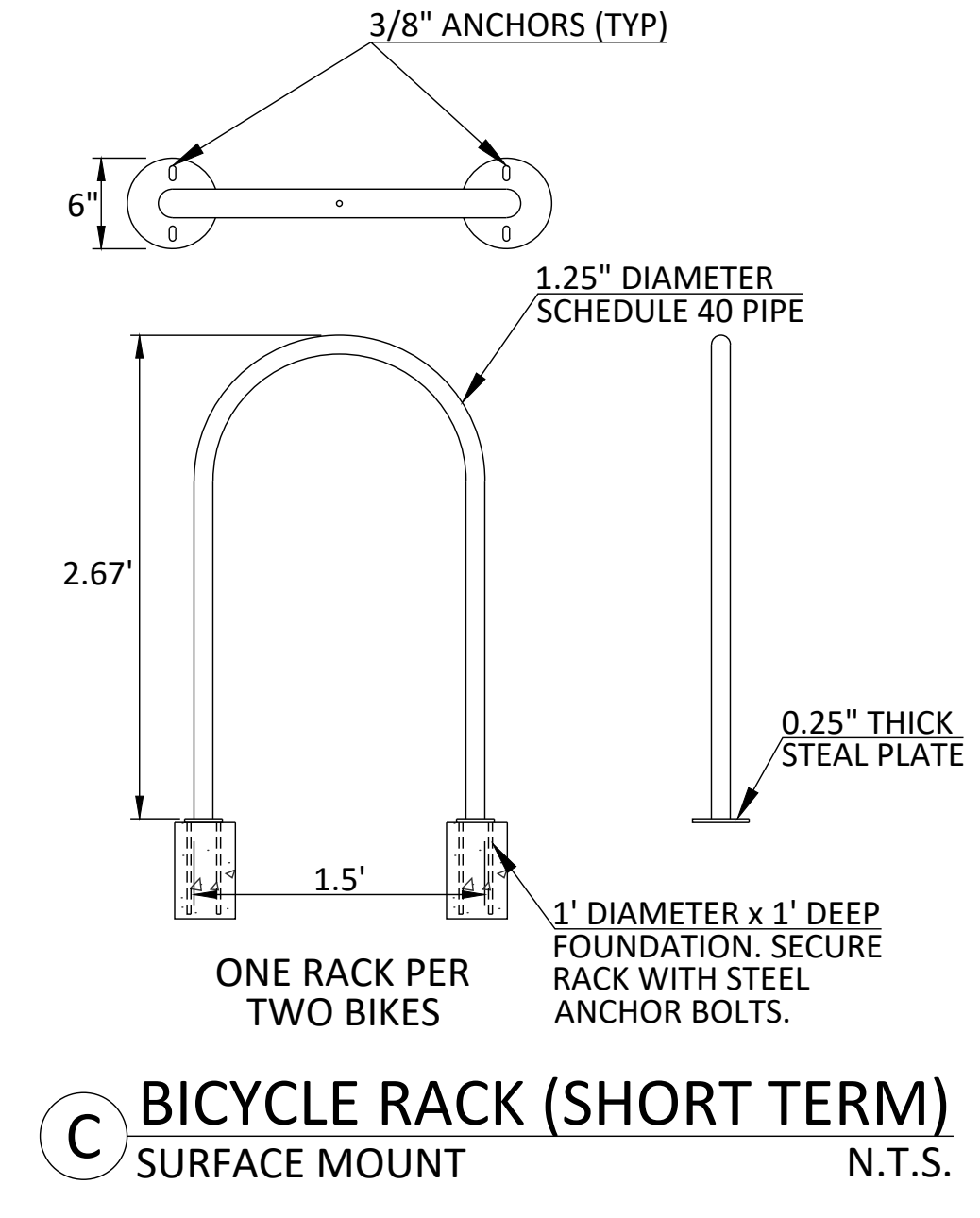
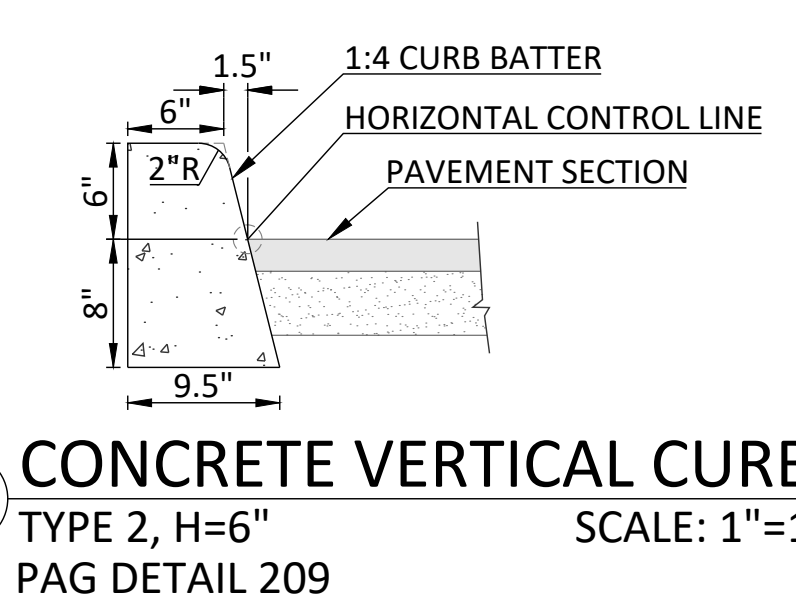
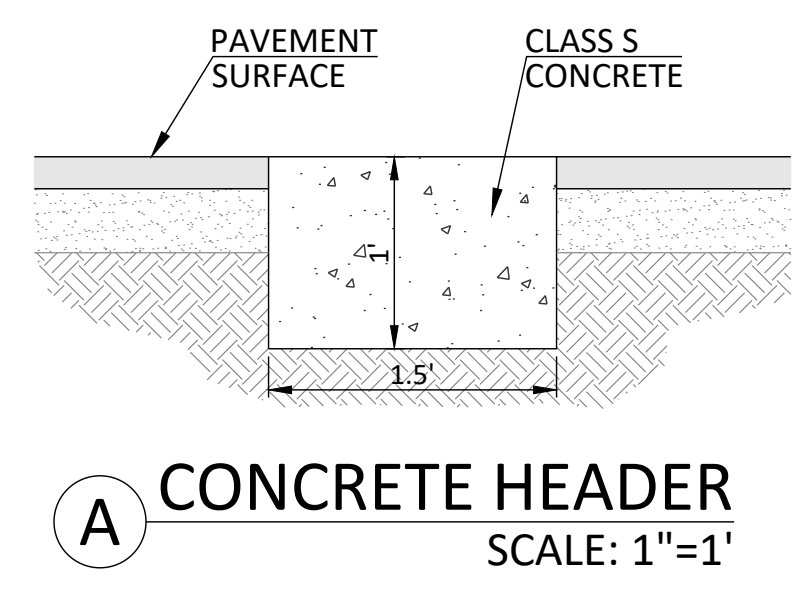

APPROVED DP



NO.	DATE	REVISION DESCRIPTION	BY	OWNER/DEVELOPER
				JULIAN DREW LOFTS, LLC P.O. BOX 43426 TUCSON, ARIZONA 85733 ATTN: MR. ROSS RULNEY PH: (520) 850-9300 E: rossrulney@gmail.com
				SITE ADDRESS 114 & 124 East Broadway Boulevard TUCSON, ARIZONA 85701

NO. 37624 KEVIN M. HALL
Professional Engineer
Arizona, U.S.A.
10/23/2020

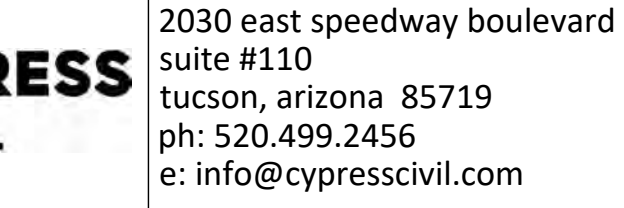

CYPRESS PROJECT NO: 20.102
2030 east speedway boulevard
suite #110
tucson, arizona 85719
ph: 520.499.2456
e: info@cypresscivil.com

**DEVELOPMENT PACKAGE for
124 EAST BROADWAY
site plan**



DP20-0148 REF: T20SA00220; RNA-DRB-20-05; HPZ-20-047

E BROADWAY BOULEVARD

ARIZONA AVENUE

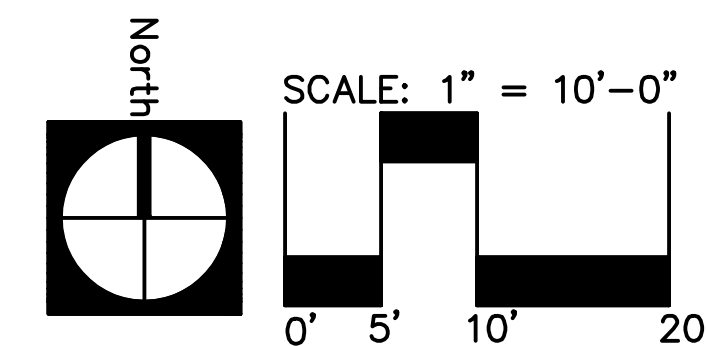
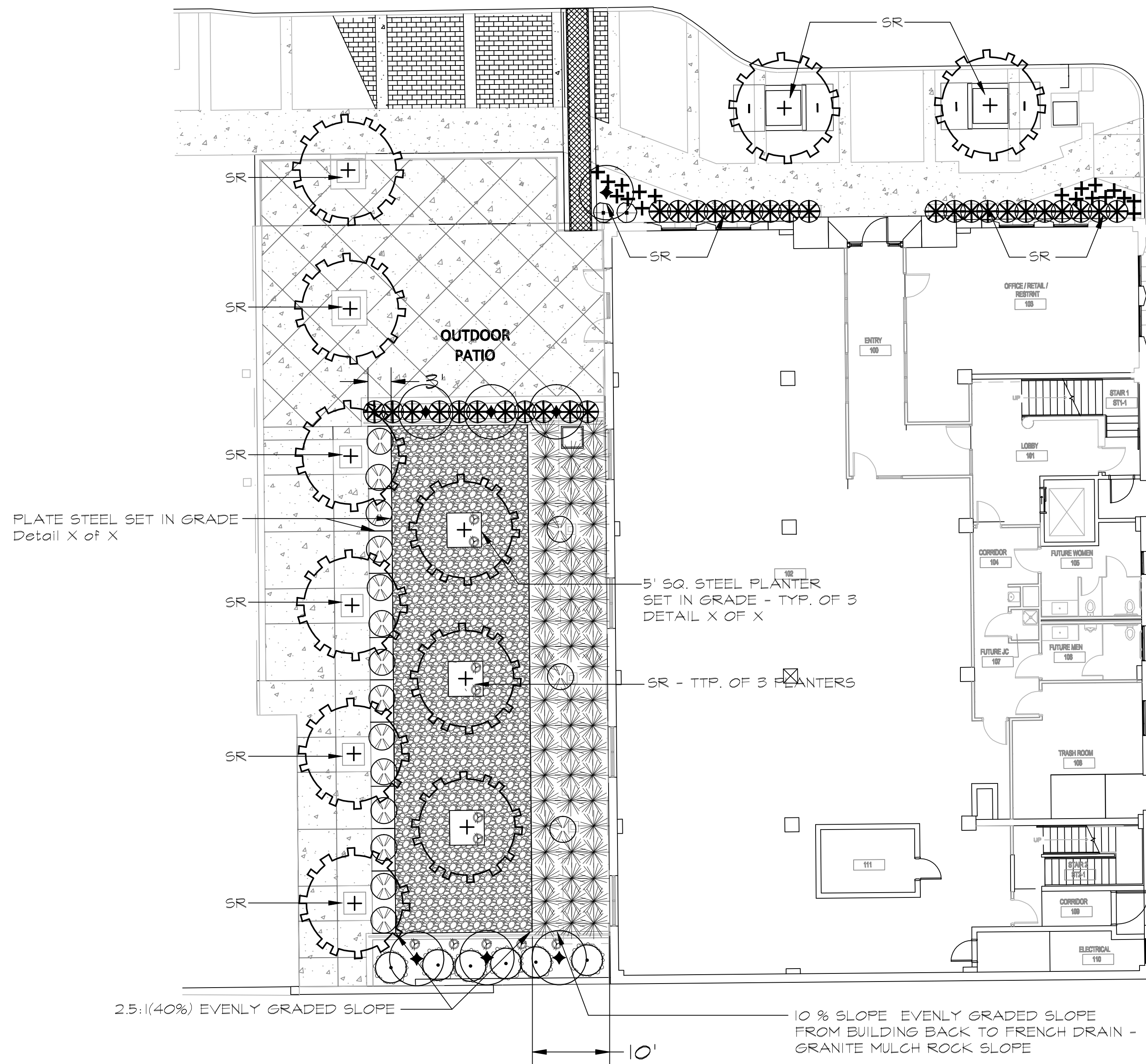

PLANT LEGEND

PLANT BOTANICAL NAME
COMMON NAME: SIZE: GPH:

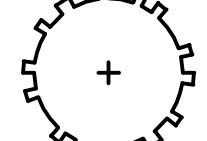
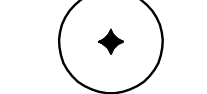
- TREES:**
-  *Pistacia chinensis*
Chinese Pistache 24" Box 8
 -  *Bauhinia lunarioides*
Anacacho Orchid Tree 24" Box 4

SHRUBS & ACCENTS SIZE: GPH:

-  *Tecoma "Orange Jubilee"*
Orange Jubilee 5 Gal. 2
-  *Hesperaloe parviflora "Perpa"*
Brakeights Red Yucca 5 Gal. 1
-  *Aloe "X"*
Blue Elf Aloe 5 Gal. 1
-  *Pedilanthus microtheca*
Lady Slipper 5 Gal. 2
-  *Cycas revoluta*
Sago Palm 5 Gal. 2
-  *Bougainvillea*
Bougainvillea 5 Gal. 2
-  *Rosa banksia "Alboplena"*
Lady Banks Rose 5 Gal. 2

INERT GROUNDCOVERS:

Granite Mulch/Screened Rock shall be placed in all landscape areas including all planters and raised planters.

SR Screened Rock: 5/8" - Apache Brown - 2" Depth

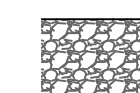
 Granite Mulch: 3"-6" Blend Apache Brown - 6" Depth - 1,500 S.F. Hand Placed

Pre-Emergent Herbicide: All landscape areas shall be treated with Surflan per-emergent herbicide or approved equal. Herbicide shall meet all applicable local, State and Federal environmental and labeling laws. Under no circumstances shall a soil sterilant be used on the site. Submit specification to Owners Representative for review and approval prior to application. Apply herbicide per manufacturer's recommendations.

All Sized Rock and Granite Mulch areas shall be watered settled.

APPROVED DP

LANDSCAPE PLAN

NO.	DATE	REVISION DESCRIPTION	BY	OWNER/DEVELOPER
				JULIAN DREW LOFTS, LLC P.O. BOX 43426 TUCSON, ARIZONA 87733 ATTN: MR. ROSS RULNEY PH: (520) 850-9300 EMAIL: rossrulney@gmail.com
				SITE ADDRESS 114 - 124 E. BROADWAY BLVD. TUCSON, ARIZONA 85701

CDRC Approved Development Package AHines2
10/23/2020
PLANNING & DEVELOPMENT SERVICES

Site/Dev Plan SCZ
 Tentative Plat ERZ
 Grading HDZ
 SWAP Fee working copy WASH
 FUP Fee Call for the Rules
 Permitted Other

1-800-702-5348
Blue State Center

EXPIRES 3/31/2021
LOT 3 AND EAST PORTION OF LOT 4, BLOCK 256 "MILITARY PLAZA" RECORDED IN BOOK 1 AT PAGE 24, MAPS AND PLATS, PIMA COUNTY RECORDS. LOCATED IN THE NORTHWEST QUARTER OF SECTION 13, T. 14 S., R 19E., G.S. R.M., CITY OF TUCSON, PIMA COUNTY, ARIZONA

DEVELOPMENT PACKAGE for
124 EAST BROADWAY

DP20-0148
REF: T20SA00220; RNA-DRB-20-05; HPZ-20-047
8 of 11

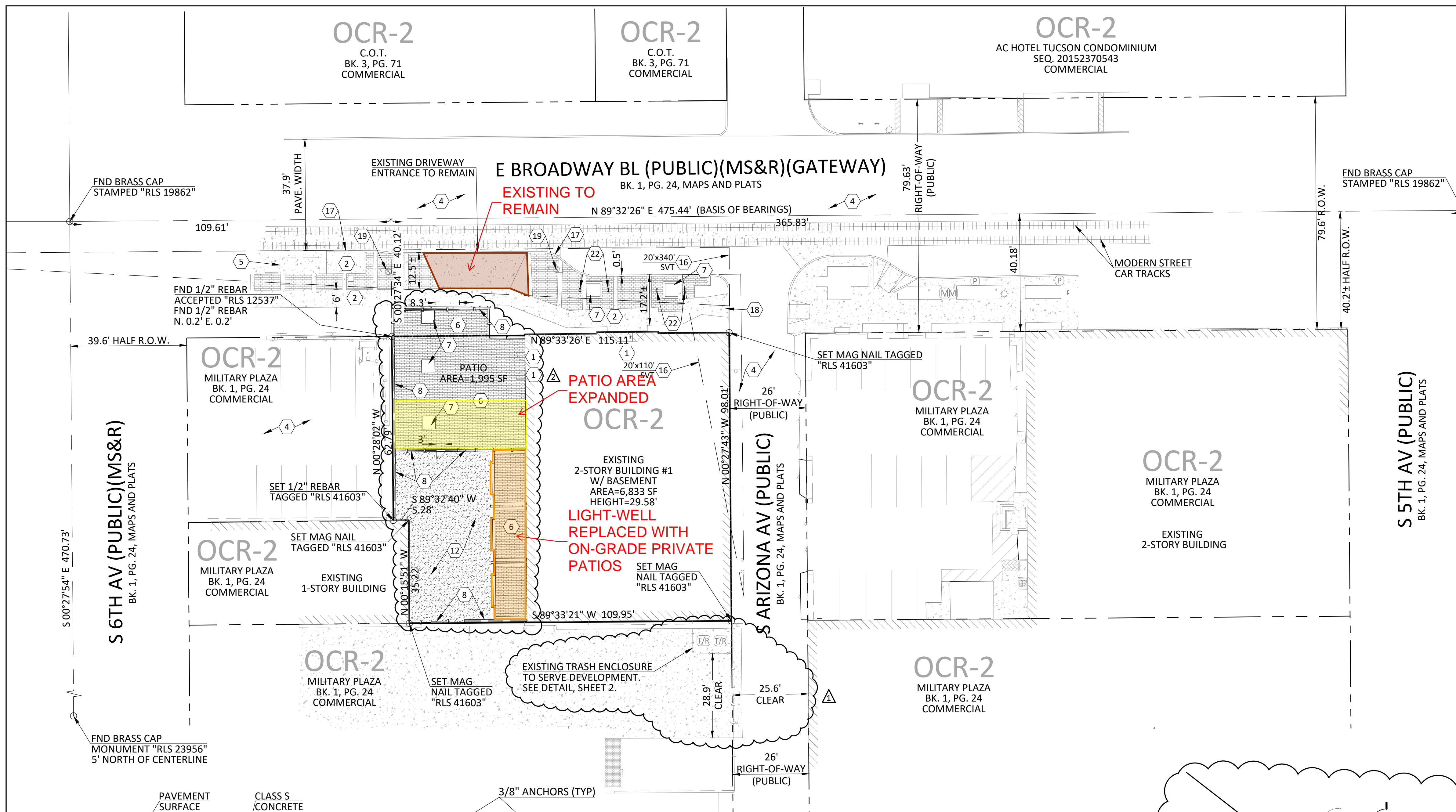

SCALE: 1"=20'

- KEYNOTES**
- 1 PRIMARY BUILDING ENTRANCE.
 - 2 EXISTING CONCRETE/SIDEWALK TO REMAIN.
 - 3 EXISTING FENCE/WALL TO REMAIN.
 - 4 EXISTING ASPHALT TO REMAIN.
 - 5 EXISTING SUN LINK SHELTER TO REMAIN.
 - 6 NEW CONCRETE PAVERS ON SAND. SEE HARDSCAPE PLAN (SHEET 6). 2% MAX. CROSS SLOPE; 5% MAX. LONGITUDINAL SLOPE.
 - 7 NEW LANDSCAPE PLANTER/SEAT WALL PER LANDSCAPE PLANS.
 - 8 NEW WALL/FENCE. OWNER/ARCHITECT TO PROVIDE DETAILS AND FINISHES.
 - 9 NEW RAILING/FENCING. OWNER/ARCHITECT TO PROVIDE DETAILS AND FINISHES.
 - 10 NEW BUILDING OVERHANG PER BUILDING PLANS.
 - 11 NEW BUILDING COLUMN PER BUILDING PLANS.
 - 12 NEW TURF/ROCK PER LANDSCAPE PLANS.
 - 16 SIGHT VISIBILITY TRIANGLE FOR PROPOSED DEVELOPMENT. SEE KEYNOTE FOR DIMENSIONS.
 - 17 EXISTING CURB TO REMAIN.
 - 18 EXISTING CURB ACCESS RAMP TO REMAIN.
 - 19 EXISTING LIGHT/STREET CAR POLE TO REMAIN.
 - 20 NEW RETAINING WALL PER SEPARATE PLAN AND PERMIT.
 - 21 NEW CONCRETE HEADER PER PAG DETAIL 213.
 - 22 NEW SHORT TERM BICYCLE RACK. SEE RACK DETAIL C, THIS SHEET. FOR RACK SPACING SEE DETAIL D, THIS SHEET.
 - 23 NEW SIDEWALK SCUPPER (TYPE 2) PER PAG DETAIL 205. SEE DETAIL E, SHEET 2. CONNECT TO BUILDING SUMP DRAIN OUTLETS.

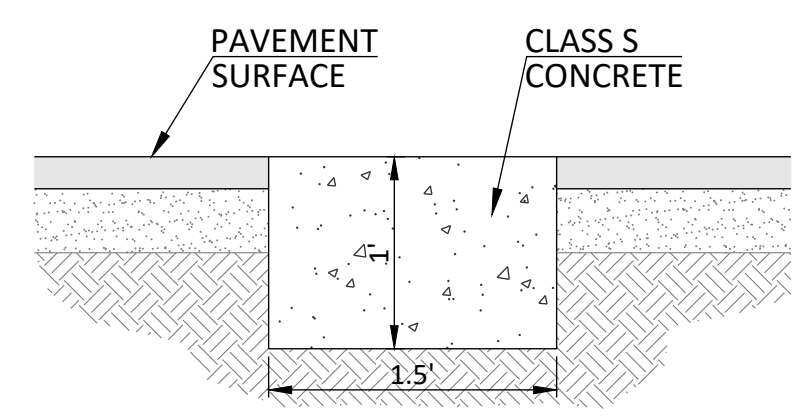

A CONCRETE HEADER
SCALE: 1"=1'

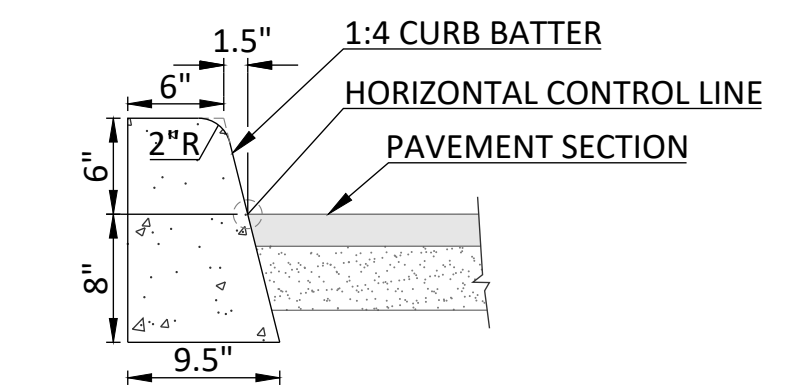

B CONCRETE VERTICAL CURB
TYPE 2, H=6" SCALE: 1"=1'
PAG DETAIL 209

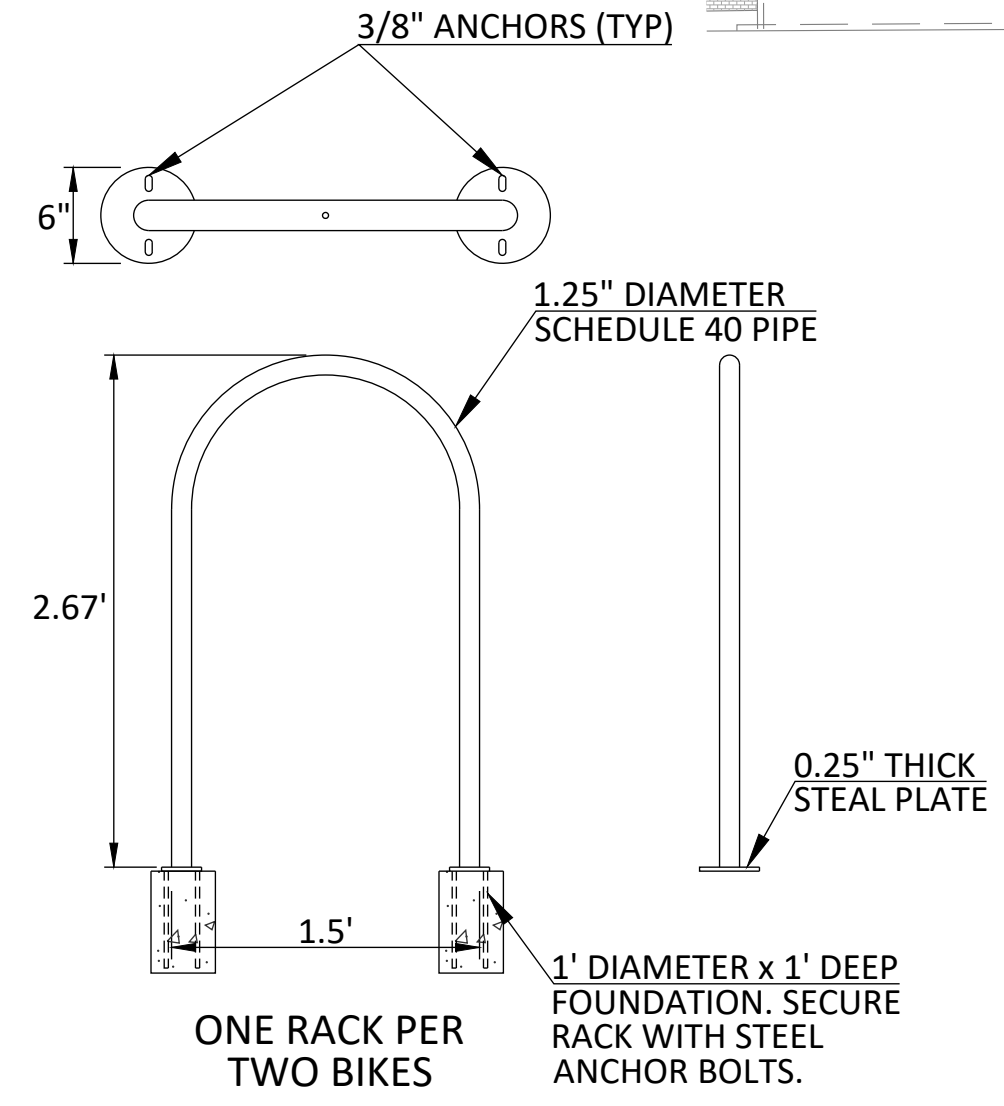

C BICYCLE RACK (SHORT TERM)
SURFACE MOUNT N.T.S.

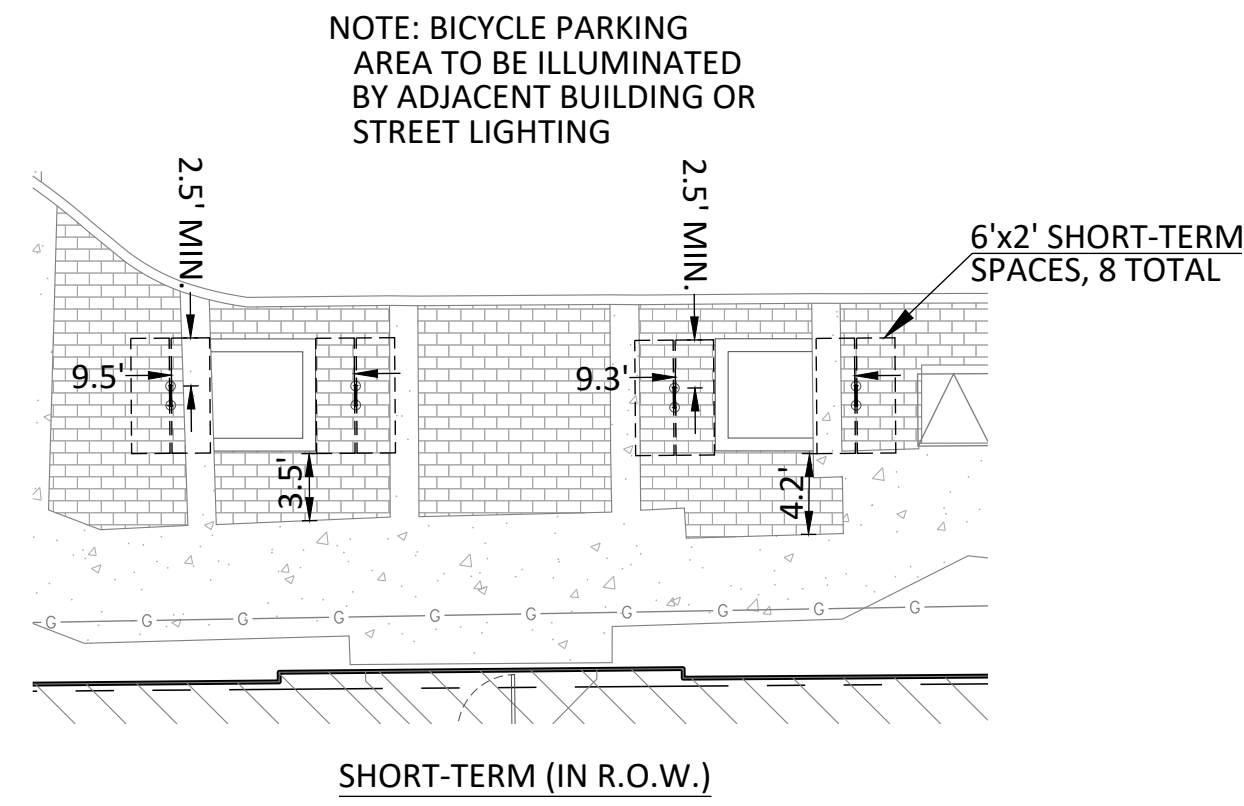

D BIKE RACK/LOCKER SPACING
SCALE: 1"=10'

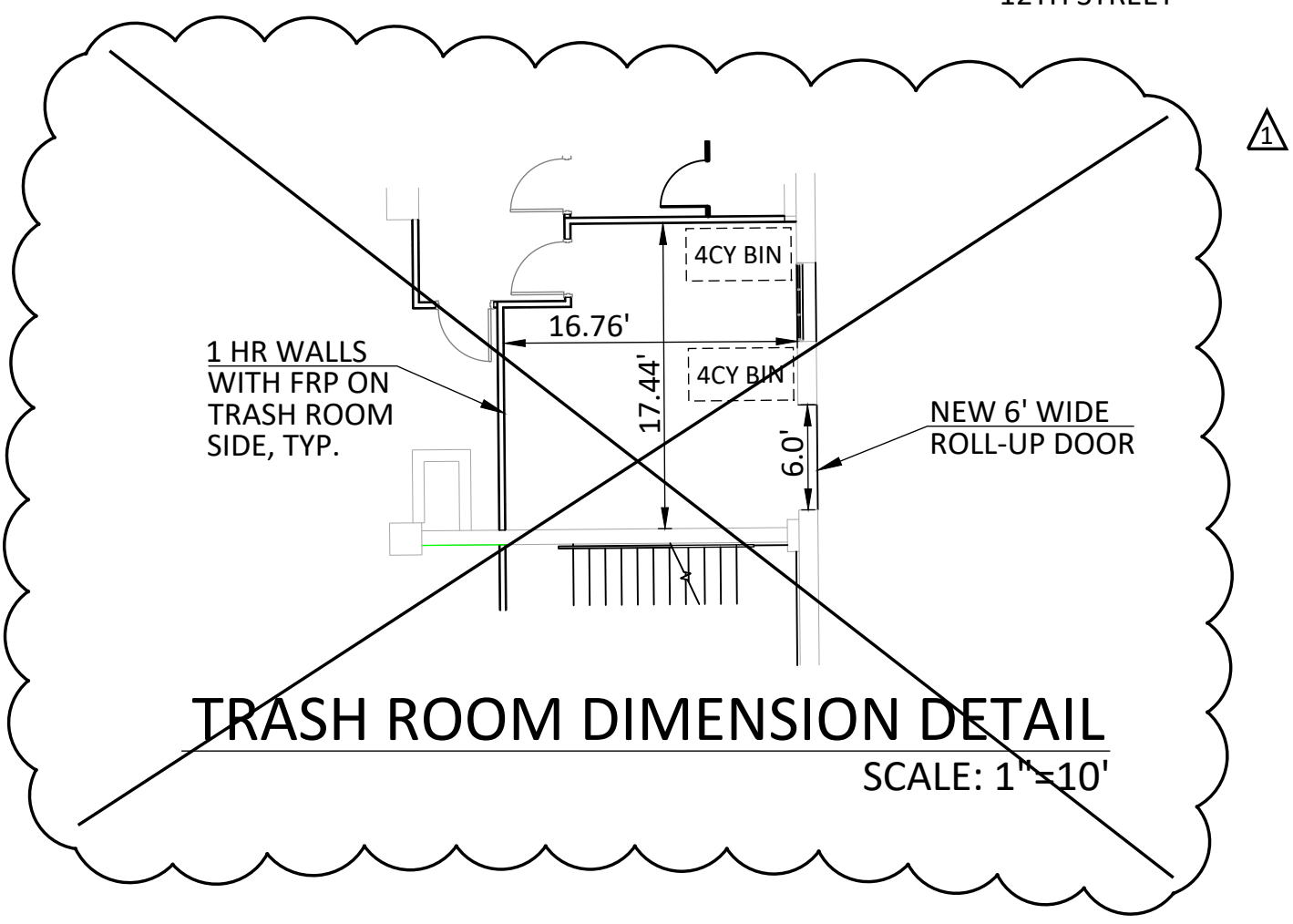

TRASH ROOM DIMENSION DETAIL
SCALE: 1"=10'

FOR REVISION #1 ONLY FOR REVISION #2 ONLY



NO.	DATE	REVISION DESCRIPTION	BY	OWNER/DEVELOPER
12-04-20		REVISE COURTYARD AREA AND REVISE TRASH COLLECTION AREA	KMH	JULIAN DREW LOFTS, LLC P.O. BOX 43426 TUCSON, ARIZONA 85733
06-24-21		REVISE COURTYARD AREA AND BUILDING USE AREAS	KMH	ATTN: MR. ROSS RULNEY PH: (520) 850-9300 E: rossrulney@gmail.com

CYPRESS PROJECT NO: 20.102

2030 east speedway boulevard suite #110
tucson, arizona 85719
ph: 520.499.2456
e: info@cypresscivil.com

CYPRESS CIVIL

SITE ADDRESS
114 & 124 East Broadway Boulevard
TUCSON, ARIZONA 85701

LOT 3 AND EAST PORTION OF LOT 4, BLOCK 256 "MILITARY PLAZA" RECORDED IN BOOK 1 AT PAGE 24, MAPS AND PLATS, PIMA COUNTY RECORDS. LOCATED IN THE NORTHEAST QUARTER OF SECTION 13, T. 14 S., R. 13 E., G.&S.R.M., CITY OF TUCSON, PIMA COUNTY, ARIZONA.

DEVELOPMENT PACKAGE for
124 EAST BROADWAY
site plan



REV 2 SUBMITTAL

DP20-0148
REF: T20SA00220; RNA-DRB-20-05; HPZ-20-047

3
10

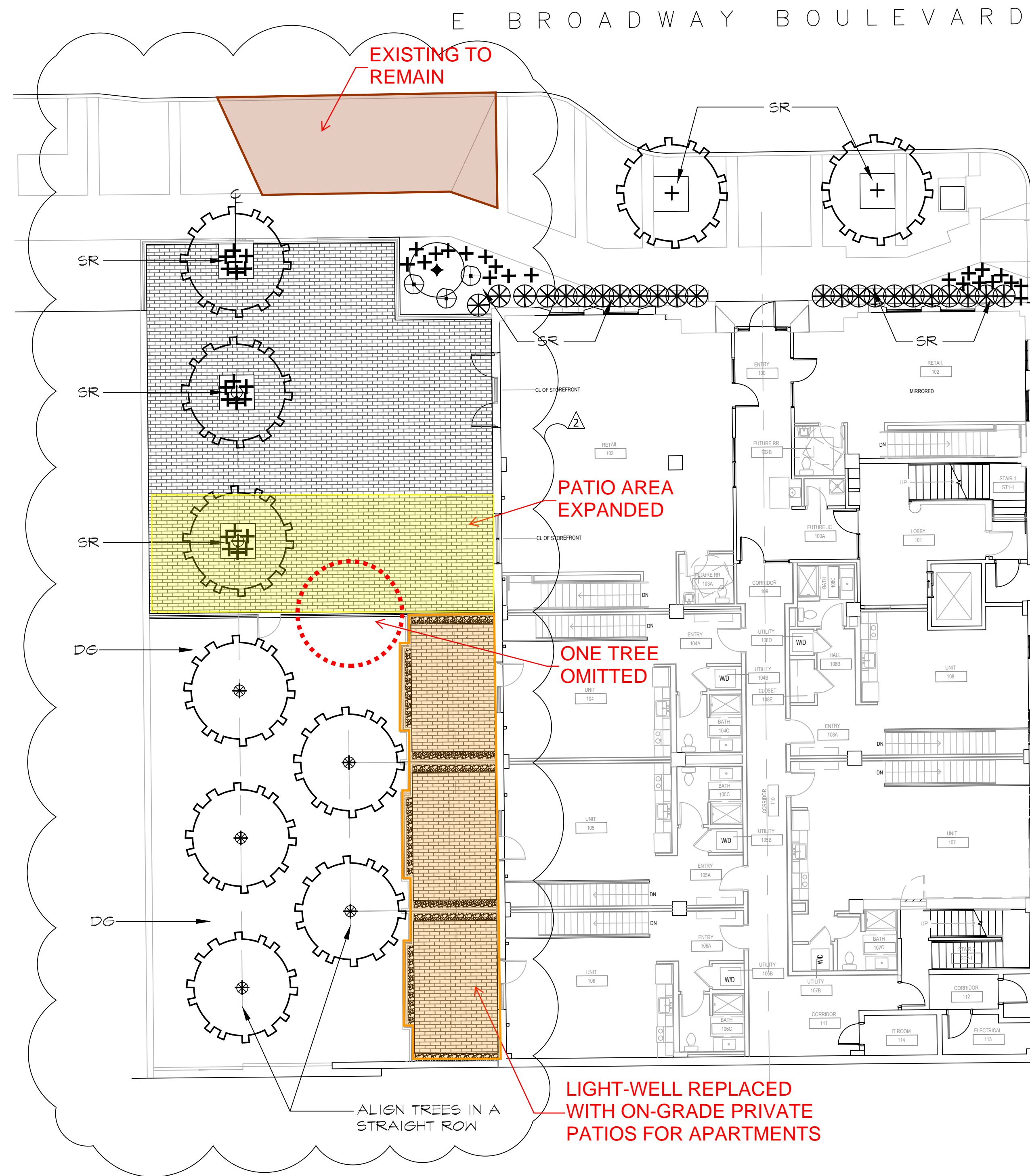

PLANT LEGEND

PLANT SYMBOL	BOTANICAL NAME COMMON NAME:	SIZE:	GPH:
	TREES: <i>Pistacia chinensis</i> Chinese Pistache	24" Box	8
	<i>Chilopsis linearis</i> - "Sweet Bubba" Desert Willow	15 Gal.	4

SHRUBS & ACCENTS	SIZE:	GPH:
	<i>Aloe "X"</i> Blue Elf Aloe	5 Gal. 1
	<i>Pedilanthus microtheca</i> Lady Slipper	5 Gal. 2
	<i>Cycas revoluta</i> Sago Palm	5 Gal. 2
	<i>Bougainvillea spectabilis</i> Bougainvillea	5 Gal. 2

INERT GROUNDCOVERS:

Decomposed Granite/Granite Mulch/Screened Rock shall be placed in all landscape areas including all planters and raised planters.

SR Screened Rock: 5/8" - Apache Brown - 2" Depth

DG Decomposed Granite 1/4" Minus - Apache Brown - 3" Depth

Granite Mulch: 1"-3" Blend Apache Brown - 3" Depth

Pre-Emergent Herbicide: All landscape areas shall be treated with Surflan per-emergent herbicide or approved equal. Herbicide shall meet all applicable local, State and Federal environmental and labeling laws. Under no circumstances shall a soil sterilant be used on the site. Submit specification to Owners Representative for review and approval prior to application. Apply herbicide per manufacturer's recommendations.

All Decomposed Granite and Sized Rock areas shall be watered settled.

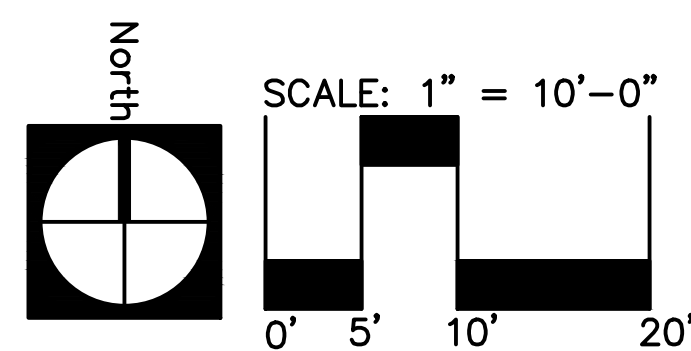

LANDSCAPE PLAN

NO. DATE	REVISION DESCRIPTION	BY	OWNER/DEVELOPER JULIAN DREW LOFTS, LLC P.O. BOX 43426 TUCSON, ARIZONA 85733 ATTN: MR. ROSS RULNEY PH: (520) 850-9300 E: rossrulney@gmail.com
8-12-21	REVISE ROW PAVING	JRH	
12-04-20	REVISE COURTYARD AREA LANDSCAPE AND IRRIGATION	JRH	
6-28-21	REVISE COURTYARD AREA LANDSCAPE AND IRRIGATION	JRH	SITE ADDRESS 114 & 124 East Broadway Boulevard TUCSON, ARIZONA 85701
JOHN HUCKO - LANDSCAPE ARCHITECT 5236 N. STONEHOUSE PL. TUCSON, ARIZONA 85750 P: (520) 400.8529 E: jhucko789@comcast.net JRH PROJECT NO: 20-13 DATE: 8-12-21			

LOT 3 AND EAST PORTION OF LOT 4, BLOCK 256 "MILITARY PLAZA" RECORDED IN BOOK 1 AT PAGE 24, MAPS AND PLATS, PIMA COUNTY RECORDS. LOCATED IN THE NORTHEAST QUARTER OF SECTION 13, T. 14 S., R. 13 E., G. & S.R.M., CITY OF TUCSON, PIMA COUNTY, ARIZONA.

**DEVELOPMENT PACKAGE for
124 EAST BROADWAY**

REV 2 SUBMITTAL



DP20-0148 REF: T20SA00220; RNA-DRB-20-05; HPZ-20-047

8 OF 10

Permit Review Details

Permit: DP20-0148
 Parcel: 11717003A

Addresses:
 124 E BROADWAY BL
 114 E BROADWAY BL

Review Status: **Active**

Review Details

Show entries Search:

Task End Date	Reviewer's Name	Type of Review	Description	Status	Comment
7/6/2021	ANY	COT NON-DSD	REAL ESTATE	Active	None
7/6/2021	ANY	ENGINEERING	REVIEW	Active	None
7/6/2021	ANY	ZONING-DECISION LETTER	WRITE DECISION LETTER	Active	None

Task End Date	Reviewer's Name	Type of Review	Description	Status	Comment
7/8/2021	MGAYOSS1	DESIGN PROFESSIONAL	REVIEW	Denied	<p>7/8/2021 - Review by María Gayosso, for compliance with design package approved under RNA-DRB-20-05/HPZ 20-047 (T20SA00220):</p> <p>Applicant is proposing to: a) Change land uses on ground floor from residential units, leaving retail space along Broadway Bl, creating new openings on the west facade; replacing the retaining wall and landscape against the west side of the building with pavers and railings. These modifications will require the applicant to request a SECOND modification to the approved design packet, requiring review by the PRS and the DRB. The request for modifications of the approved design package for this project include:</p> <ol style="list-style-type: none"> 1) Completed application form: https://www.tucsonaz.gov/files/pdsd/Special_Districts_Application_R19-20_FILLABLE_PDF.pdf; 2) Letter of authorization from property owner; 3) Letter describing the scope of work, LISTING the proposed modifications to land uses, floor plans, and elevations, landscaping, indicating how proposal complies with IID and historic preservation requirements; 4) Decision notices previously issued; 5) Cut sheets of proposed materials; 6) Revised renderings; and 7) Other materials are needed/required. <p>Design review fees will be determined at the time of submittal of requested modifications to the design package.</p>
7/30/2021	FRANK PODGORSKI	HPZ ADVISORY BOARD	HPZ ADVISORY BOARD DATE	Active	None
8/2/2021	JPEELDA1	COT NON-DSD	FIRE	Approved	None
8/2/2021	STEVE SHIELDS	ZONING	REVIEW	Reqs Change	Until the DP is approved by Historic & Design Professional Zoning can approve.

REV 2 DP COMMENTS

Task End Date	Reviewer's Name	Type of Review	Description	Status	Comment
8/4/2021	SBEASLE1	COT NON-DSD	TRAFFIC	Approved	Email from: David Stiffey To: CDRC Wed 8/4/2021 9:31 AM No Comments. David Stiffey City of Tucson

Showing 1 to 8 of 8 entries

Previous

1

Next





SPECIAL DISTRICTS APPROVAL
 NRoss1 12/08/2020

CASE# RNA-DRB-20-05
 ACTIVITY# T20SA00220
 RELATED# DP20-0148

PLANNING AND DEVELOPMENT SERVICES DEPARTMENT

<input type="checkbox"/> HD	<input checked="" type="checkbox"/> DESIGN PACKAGE
<input checked="" type="checkbox"/> RNA	<input type="checkbox"/> SITE PLAN DEVELOPMENT PLAN
<input type="checkbox"/> UOD	<input type="checkbox"/> ELEVATIONS
<input type="checkbox"/> HPZ	<input type="checkbox"/> APPROVED WITH CONDITIONS
<input type="checkbox"/> NPZ	<input type="checkbox"/> OTHER



VFW R NOVATION

WEST ELEVATION
 SCALE: 1/8" = 1'-0"

Engberg Anderson n Project N . 203177.00



DOOR TO REPLACE GLAZED AREA
(TYPICAL ALL THREE UNITS)

SOLID METAL
PRIVACY WALL

PERFORATED METAL
PRIVACY SCREEN

VFW RENOVATION PHASE II

West Elevation - COT 08.13.21 REV 09-09-21
SCALE: 1/8" = 1'-0"

Engberg Anderson Project No. 203177.03

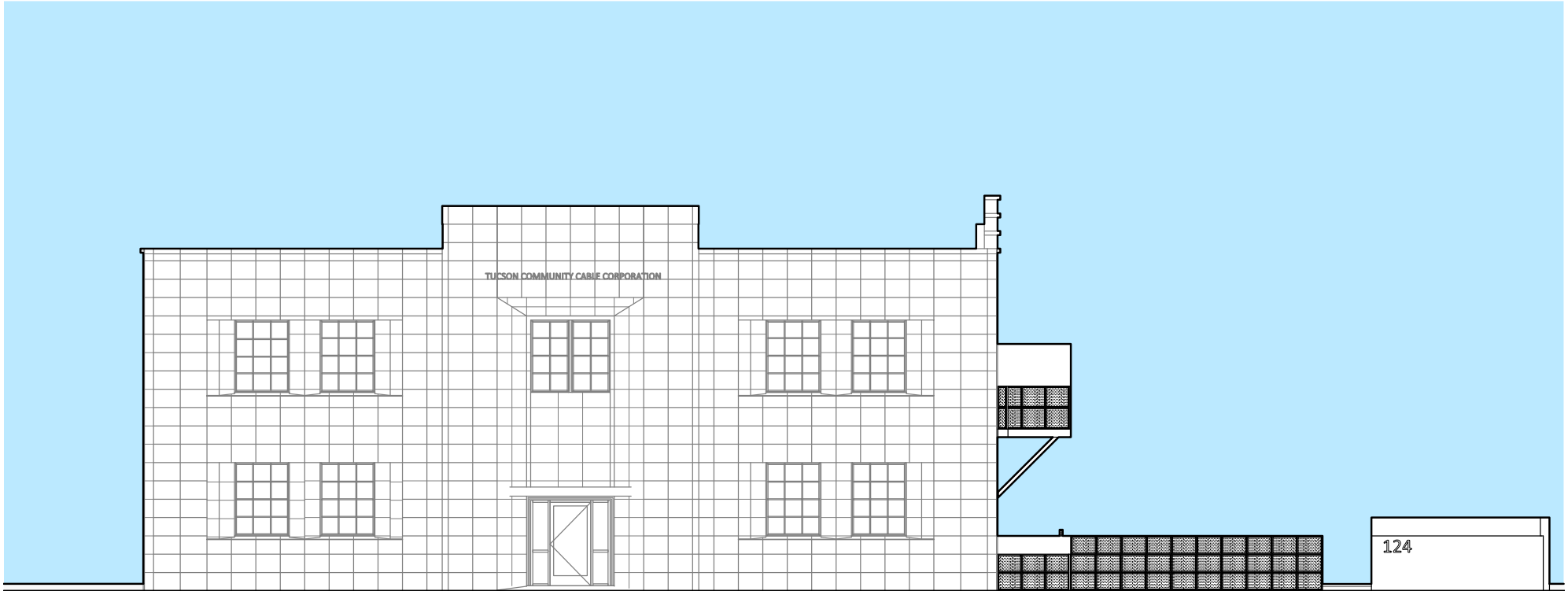

SPECIAL DISTRICTS APPROVAL
 NRoss1 12/08/2020

CASE# RNA-DRB-20-05
 ACTIVITY# T20SA00220
 RELATED# DP20-0148

PLANNING AND DEVELOPMENT SERVICES DEPARTMENT

<input type="checkbox"/> HD	<input checked="" type="checkbox"/> DESIGN PACKAGE
<input checked="" type="checkbox"/> RNA	<input type="checkbox"/> SITE PLAN/DEVELOPMENT PLAN
<input type="checkbox"/> UOD	<input type="checkbox"/> ELEVATIONS
<input type="checkbox"/> HPZ	<input type="checkbox"/> APPROVED WITH CONDITIONS
<input type="checkbox"/> SPZ	<input type="checkbox"/> OTHER

VFW R NOVATION

NORTH ELEVATION
 SCALE: 1/8" = 1'-0"

ngberg Anders n Project N . 203177.00





VFW RENOVATION PHASE II

North Elevation - COT 08.13.21
SCALE: 1/8" = 1'-0"

Engberg Anderson Project No. 203177.03

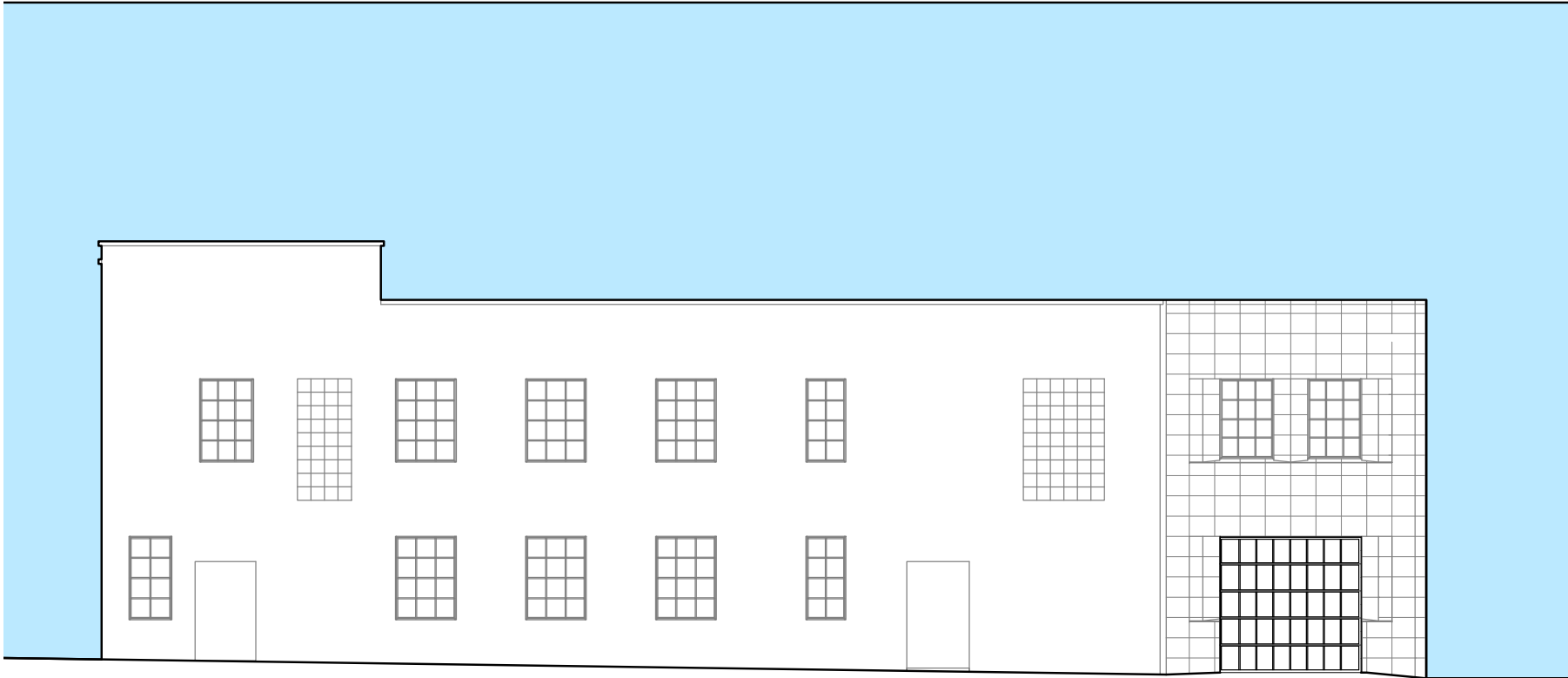

SPECIAL DISTRICTS APPROVAL
 NRoss1 12/08/2020

CASE# RNA-DRB-20-05
 ACTIVITY# T20SA00220
 RELATED# DP20-0148

PLANNING AND DEVELOPMENT SERVICES DEPARTMENT

<input type="checkbox"/> HD	<input checked="" type="checkbox"/> DESIGN PACKAGE
<input checked="" type="checkbox"/> RNA	<input type="checkbox"/> SITE PLAN/DEVELOPMENT PLAN
<input type="checkbox"/> LOD	<input type="checkbox"/> ELEVATIONS
<input type="checkbox"/> SIZE	<input type="checkbox"/> APPROVED WITH CONDITIONS
<input type="checkbox"/> NPZ	<input type="checkbox"/> OTHER

VFW R NOVATION

EAST ELEVATION
 SCALE: 1/8" = 1'-0"



Engberg Anderson n Project N . 203177.00

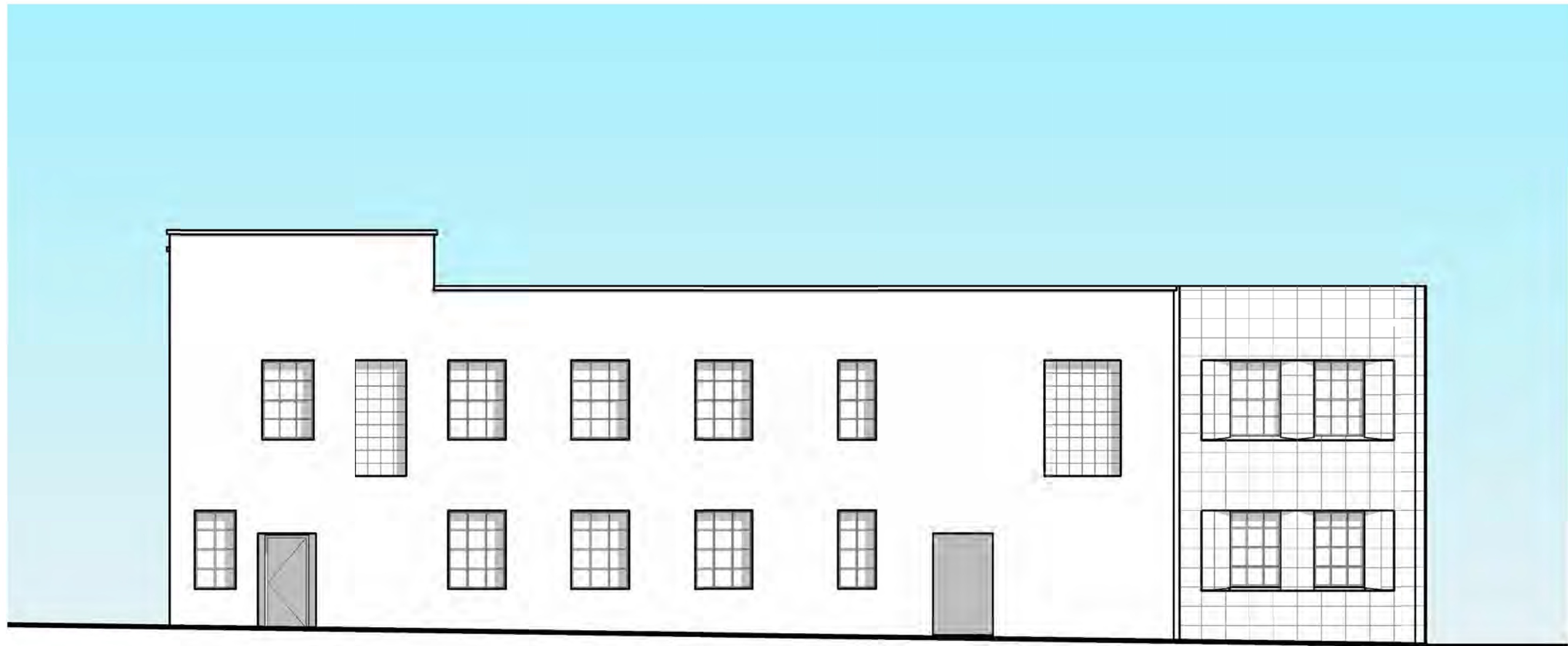

VFW RENOVATION PHASE II

East Elevation - COT 08.13.21
SCALE: 1/8" = 1'-0"

Engberg Anderson Project No. 203177.03



REV 2 SUBMITTAL









REV 2 SUBMITTAL



Engberg
Anderson
ARCHITECTS



ASSESSOR'S RECORD MAP

TUCSON RESUB MILITARY PLAZA

BLOCKS 256-261

117-17

