

**PLAN**  
6"x 6" Steel Tube

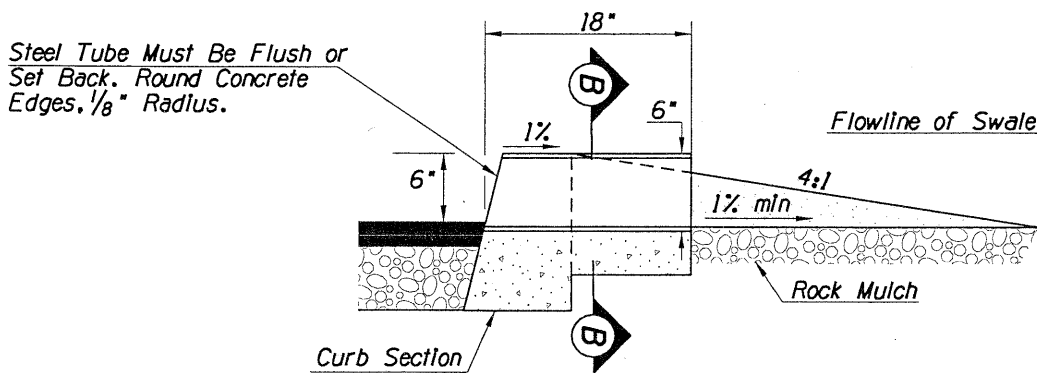

Steel Tube Must Be Flush or Set Back. Round Concrete Edges,  $\frac{1}{8}$ " Radius.

**SECTION A-A**  
6"x 6" Steel Tube

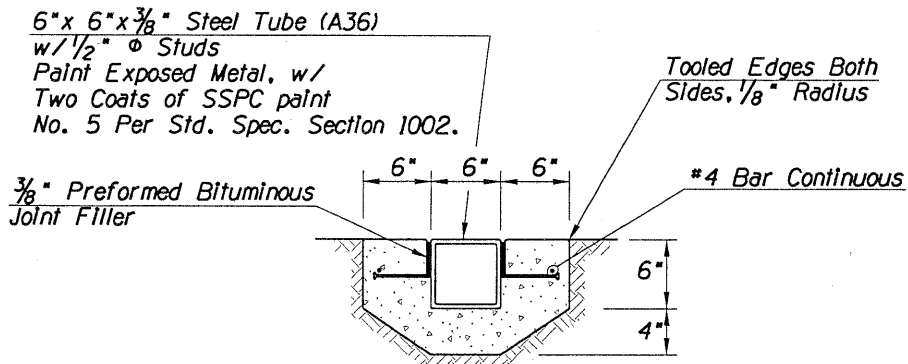

6"x 6"x  $\frac{3}{8}$ " Steel Tube (A36)  
w/  $\frac{1}{2}$ "  $\phi$  Studs  
Paint Exposed Metal, w/  
Two Coats of SSPC paint  
No. 5 Per Std. Spec. Section 1002.

Tooled Edges Both Sides,  $\frac{1}{8}$ " Radius

$\frac{3}{8}$ " Preformed Bituminous Joint Filler

#4 Bar Continuous

**SECTION B-B**  
6"x 6" Steel Tube

SMALL SCUPPER - 6"  
FIGURE 3